

## 416.

# Vekoma Suspended Looping Coaster spindle failure

Vekoma has issued the accompanying service bulletin relating to its Suspended Looping Coaster model no. Mk 1201. The bulletin provides detailed information on the (dis)assembly of the main axle spindle and rear axle spindle and also adds a chapter in order to pay extra attention during (dis)assembly of the spindle following a spindle failure during disassembly at one of the company's customers.

*The information contained within is that of the manufacturer and not NAFLIC. When following the advice from the manufacturer, you are reminded of your duties and responsibilities under HSG175 regarding modifications.*

Committee Members: Mr. D Dadswell (Chairman), Mr. A Mellor (Secretary), Mr. P Smith, Mr. J Green, Mr. D Cox, Mr. M Thirkettle, Mr. I Davies, Mr. J Shilling & Mr. D Inman

[www.naflic.co.uk](http://www.naflic.co.uk)

Supported By:





Issuing Entity:	Bulletin No.: SB-002_04
Vekoma Rides Parts & Services B.V.	Release Date: 30-03-2016
Schaapweg 18	Effective Date: Immediately
6063 BA VLODROP	Supersedes: 2-SB-002-311006/ 1-SB-002-060214/ 2-SB002-170214
The Netherlands	Completion Date: 01-01-2017
CoC Number: 12049585	

# Service Bulletin

Original Ride Manufacturer: Vekoma Rides Manufacturing B.V.	Affected Production Dates: All rides as mentioned in Table 1
Ride Name: Suspended Looping Coaster	Affected Serial Nos: Table 1
Model No: Mk1201	476

<p>Abstract of issue:</p> <p><b>(Dis)Assembly procedure vertical spindle main axle Suspended Looping Coaster.</b></p>
<p>Reason for release:</p> <p>This service bulletin gives detailed information about (dis)assembling the main axle spindle and rear axle spindle. Also a chapter is added in order to pay extra attention during (dis)assembly of the spindle because a spindle failed during disassembly at one of our customers.</p>
<p>Action to be taken:</p> <p>Add these instructions to your operation and maintenance manual.</p>

Date	Revision date	Comment
06-02-2014	01	Service bulletin updated. Section 1.1.1, item 5 updated.
17-02-2014	02	Vekoma Manufacturing B.V. and Vekoma International B.V. replaced by Vekoma Rides Manufacturing B.V..
29-03-2016	03	Chapter 2 and affected serial Nos added to this Service Bulletin. Several (small) changes made to the content
30-03-2016	04	Small changes due to final check

\* In the interests of safety and as a service to the industry, Vekoma Rides Parts & Services B.V. issues technical information bulletins for the benefit of owners of amusement rides that are manufactured by Vekoma Rides Manufacturing B.V. (both companies are members of the Vekoma Rides B.V.). These bulletins may also contain technical information, on parts or modifications relating to amusement rides, manufactured by *Vekoma International B.V.* and / or *Vekoma Manufacturing B.V.* These are dissolved companies which have no legal relationship whatsoever with the Vekoma Rides B.V.

Vekoma Rides B.V. including its affiliated companies, agents and employees make no warranties and assume no responsibility for any misapplication or misinterpretation of the information provided, ride down time, consequential damages, loss, injuries, causes of action, claims, demands and expenses (including legal fees), of any kind or nature, arising directly or indirectly, in whole or in part, from or in relation to this technical information bulletin; nor for any amusement ride equipment built by any manufacturer(s) other than Vekoma Rides Manufacturing B.V.

All information relating to amusement rides, parts or modifications built or carried out by manufacturers other than Vekoma Rides Manufacturing B.V. and/or marked with an asterisk "\*" are recommendations only and are not to be considered in any way to be advisory or mandatory, relied upon, nor imply any obligations or liabilities whatsoever.

## 2.1 Failure Mode and Effect Analysis

Although the vertical spindle broke during disassembly, we like to emphasize that even if the thread of the nut would fail during operation there is no direct risk to the passenger. This will be demonstrated with help of a Failure Mode and Effect Analysis (FMEA).

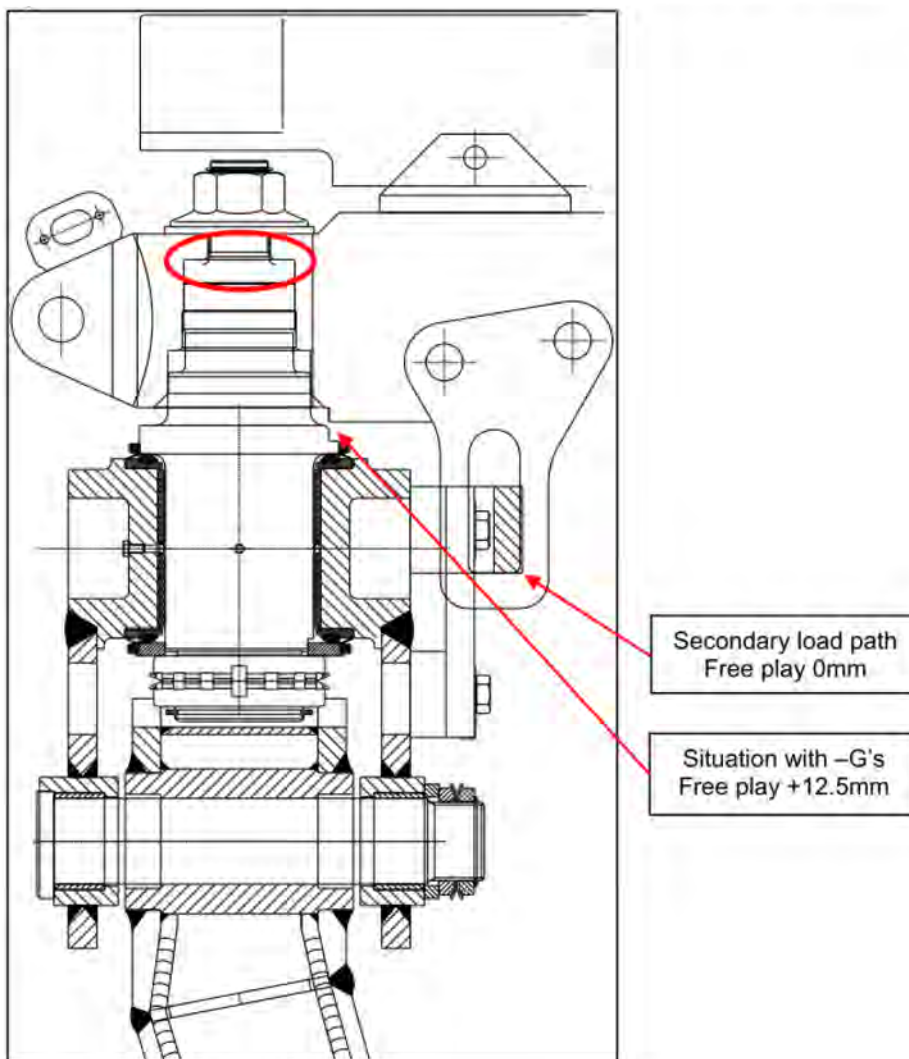

Figure 4: Failure description

\* In the interests of safety and as a service to the industry, Vekoma Rides Parts & Services B.V. issues technical information bulletins for the benefit of owners of amusement rides that are manufactured by Vekoma Rides Manufacturing B.V. (both companies are members of the Vekoma Rides B.V.). These bulletins may also contain technical information, on parts or modifications relating to amusement rides, manufactured by *Vekoma International B.V.* and / or *Vekoma Manufacturing B.V.* These are dissolved companies which have no legal relationship whatsoever with the Vekoma Rides B.V.

Vekoma Rides B.V. including its affiliated companies, agents and employees make no warranties and assume no responsibility for any misapplication or misinterpretation of the information provided, ride down time, consequential damages, loss, injuries, causes of action, claims, demands and expenses (including legal fees), of any kind or nature, arising directly or indirectly, in whole or in part, from or in relation to this technical information bulletin; nor for any amusement ride equipment built by any manufacturer(s) other than Vekoma Rides Manufacturing B.V.

All information relating to amusement rides, parts or modifications built or carried out by manufacturers other than Vekoma Rides Manufacturing B.V. and/or marked with an asterisk "\*" are recommendations only and are not to be considered in any way to be advisory or mandatory, relied upon, nor imply any obligations or liabilities whatsoever.





Issuing Entity:	Bulletin No.: SB-002_04
Vekoma Rides Parts & Services B.V.	Release Date: 30-03-2016
Schaapweg 18	Effective Date: Immediately
6063 BA VLODROP	Supersedes: 2-SB-002-311006/ 1-SB-002-060214/ 2-SB002-170214
The Netherlands	Completion Date: 01-01-2017
CoC Number: 12049585	

The FMEA shows in case the spindle would fail at the failure location during operation the spindle will remain in contact with both the chassis as well as the main axle due to the overlap of the bores (see figure 4). In case the train will experience negative g-forces the play at the secondary load path will decrease to 0mm leading to contact between the safety brace of the main beam and the main axle. This means the play between chassis and main axle will increase by 12.5mm. For this failure the secondary load path still has sufficient strength.

Additionally the spindle has a press fit into the chassis so it is questionable whether the chassis will slide over the spindle due to the negative g-forces or not. Failure effect remains the same as explained above.

Conclusion from this is in case the spindle would fail at the failure position this is not a safety critical event. Therefore it is safe to continue operation while the investigation is still ongoing.

\* In the interests of safety and as a service to the industry, Vekoma Rides Parts & Services B.V. issues technical information bulletins for the benefit of owners of amusement rides that are manufactured by Vekoma Rides Manufacturing B.V. (both companies are members of the Vekoma Rides B.V.). These bulletins may also contain technical information, on parts or modifications relating to amusement rides, manufactured by *Vekoma International B.V.* and / or *Vekoma Manufacturing B.V.* These are dissolved companies which have no legal relationship whatsoever with the Vekoma Rides B.V.

Vekoma Rides B.V. including its affiliated companies, agents and employees make no warranties and assume no responsibility for any misapplication or misinterpretation of the information provided, ride down time, consequential damages, loss, injuries, causes of action, claims, demands and expenses (including legal fees), of any kind or nature, arising directly or indirectly, in whole or in part, from or in relation to this technical information bulletin, nor for any amusement ride equipment built by any manufacturer(s) other than Vekoma Rides Manufacturing B.V.

All information relating to amusement rides, parts or modifications built or carried out by manufacturers other than Vekoma Rides Manufacturing B.V. and/or marked with an asterisk "\*" are recommendations only and are not to be considered in any way to be advisory or mandatory, relied upon, nor imply any obligations or liabilities whatsoever.

Issuing Entity:	Bulletin No.: SB-002_04
Vekoma Rides Parts & Services B.V.	Release Date: 30-03-2016
Schaapweg 18	Effective Date: Immediately
6063 BA VLODROP	Supersedes: 2-SB-002-311006/ 1-SB-002-060214/ 2-SB002-170214
The Netherlands	Completion Date: 01-01-2017
CoC Number: 12049585	

## 2.2 Disassembly of the vertical spindle

Assembly of the spindle needs to be performed according to chapter 1.1 of this service bulletin.

For disassembly of the flange nut on top of the main beam, proper tooling shall be used. For example a hydraulic torque wrench or torque multiplier in combination with a adequate socket. Do not use self made tooling. Always loosen the flange nut with a tool that is placed in plane with the chassis.

Before disassembly the vertical spindle from the chassis it is advisable to heat the main beam head to a maximum of 40°C above ambient temperature. After heating the chassis, use a press to disassemble the vertical spindle out of the chassis (no excessive shock loads on the head of the spindle shall be applied).

After every disassembly of the vertical spindle always check the spindle by means of VT. This action shall be applied in addition to the OMM.

For disassembly of the KM nut at the bottom of the vertical spindle use proper tooling (SKF). Other tooling will damage the KM nuts which result in premature failure. The KM nut will break. See also figure 4.



**If you have any doubt or questions about the (dis)assembly procedure of the vertical spindle described in this Service Bulletin, please contact VRP&S.**



**Figure 5: Broken KM nut due to use of improper tooling (assembly or disassembly)**

\* In the interests of safety and as a service to the industry, Vekoma Rides Parts & Services B.V. issues technical information bulletins for the benefit of owners of amusement rides that are manufactured by Vekoma Rides Manufacturing B.V. (both companies are members of the Vekoma Rides B.V.). These bulletins may also contain technical information, on parts or modifications relating to amusement rides, manufactured by *Vekoma International B.V.* and / or *Vekoma Manufacturing B.V.* These are dissolved companies which have no legal relationship whatsoever with the Vekoma Rides B.V.

Vekoma Rides B.V. including its affiliated companies, agents and employees make no warranties and assume no responsibility for any misapplication or misinterpretation of the information provided, ride down time, consequential damages, loss, injuries, causes of action, claims, demands and expenses (including legal fees), of any kind or nature, arising directly or indirectly, in whole or in part, from or in relation to this technical information bulletin; nor for any amusement ride equipment built by any manufacturer(s) other than Vekoma Rides Manufacturing B.V.

All information relating to amusement rides, parts or modifications built or carried out by manufacturers other than Vekoma Rides Manufacturing B.V. and/or marked with an asterisk "\*" are recommendations only and are not to be considered in any way to be advisory or mandatory, relied upon, nor imply any obligations or liabilities whatsoever.



Issuing Entity:	Bulletin No.: SB-002_04
Vekoma Rides Parts & Services B.V.	Release Date: 30-03-2016
Schaapweg 18	Effective Date: Immediately
6063 BA VLODROP	Supersedes: 2-SB-002-311006/ 1-SB-002-060214/ 2-SB002-170214
The Netherlands	Completion Date: 01-01-2017
CoC Number: 12049585	

Details of issue continued:

**According to the ASTM F853/ F1193 latest revision:**

Supplemental bulletins delivered by the manufacturer to the owner / operator that were not provided at the time of hand over of the amusement ride and contain new information or newly recommended inspections or testing, or both, will be released as a Safety Alert, Service Bulletin or an Notification, with the following criteria in order to carry the force and effect of this practice:

- “Safety Alert” For notifications that recommend immediate action.
- “Service Bulletin” For notifications that do not recommend immediate action but do recommend future action.
- “Notification” For notifications that do not necessarily recommend future action but are promulgation of information.



For additional information contact Vekoma Rides Parts & Services B.V.:

P.O. Box 8006, 6060 AA Posterholt  
Schaapweg 18, 6063 BA Vlodrop,  
The Netherlands

Tel: +31 (0) 475-409222 (office hours)  
Cellphone: +31 (0) 6-10917506 (outside office hours)  
Fax: +31 (0) 475-403415

Email: [service@vekoma.com](mailto:service@vekoma.com)

Copyright © 2014

\* In the interests of safety and as a service to the industry, Vekoma Rides Parts & Services B.V. issues technical information bulletins for the benefit of owners of amusement rides that are manufactured by Vekoma Rides Manufacturing B.V. (both companies are members of the Vekoma Rides B.V.). These bulletins may also contain technical information, on parts or modifications relating to amusement rides, manufactured by *Vekoma International B.V.* and / or *Vekoma Manufacturing B.V.* These are dissolved companies which have no legal relationship whatsoever with the Vekoma Rides B.V.

Vekoma Rides B.V. including its affiliated companies, agents and employees make no warranties and assume no responsibility for any misapplication or misinterpretation of the information provided, ride down time, consequential damages, loss, injuries, causes of action, claims, demands and expenses (including legal fees), of any kind or nature, arising directly or indirectly, in whole or in part, from or in relation to this technical information bulletin; nor for any amusement ride equipment built by any manufacturer(s) other than Vekoma Rides Manufacturing B.V.

All information relating to amusement rides, parts or modifications built or carried out by manufacturers other than Vekoma Rides Manufacturing B.V. and/or marked with an asterisk "\*" are recommendations only and are not to be considered in any way to be advisory or mandatory, relied upon, nor imply any obligations or liabilities whatsoever.





Issuing Entity:	Bulletin No.: SB-002_04
Vekoma Rides Parts & Services B.V.	Release Date: 30-03-2016
Schaapweg 18	Effective Date: Immediately
6063 BA VLODROP	Supersedes: 2-SB-002-311006/ 1-SB-002-060214/ 2-SB002-170214
The Netherlands	Completion Date: 01-01-2017
CoC Number: 12049585	

Details of issue continued:

IB-nr.	Original Ride Manufacturer	Project number
32001	Vekoma International B.V./Vekoma Manufacturing B.V.	92604
32002	Vekoma International B.V./Vekoma Manufacturing B.V.	93144
32003	Vekoma International B.V./Vekoma Manufacturing B.V.	93137
32004	Vekoma International B.V./Vekoma Manufacturing B.V.	94103
32005	Vekoma International B.V./Vekoma Manufacturing B.V.	94117
32007	Vekoma International B.V./Vekoma Manufacturing B.V.	94119
32008	Vekoma International B.V./Vekoma Manufacturing B.V.	94124
32009	Vekoma International B.V./Vekoma Manufacturing B.V.	94133
32010	Vekoma International B.V./Vekoma Manufacturing B.V.	94136
32011	Vekoma International B.V./Vekoma Manufacturing B.V.	95107
32012	Vekoma International B.V./Vekoma Manufacturing B.V.	96398
32013	Vekoma International B.V./Vekoma Manufacturing B.V.	95164
32014	Vekoma International B.V./Vekoma Manufacturing B.V.	95170
32015	Vekoma International B.V./Vekoma Manufacturing B.V.	96350
32016	Vekoma International B.V./Vekoma Manufacturing B.V.	96362
32017	Vekoma International B.V./Vekoma Manufacturing B.V.	96344
32018	Vekoma International B.V./Vekoma Manufacturing B.V.	96356
32019	Vekoma International B.V./Vekoma Manufacturing B.V.	96289
32020	Vekoma International B.V./Vekoma Manufacturing B.V.	97119
32021	Vekoma International B.V./Vekoma Manufacturing B.V.	97103
32022	Vekoma International B.V./Vekoma Manufacturing B.V.	97163
32023	Vekoma International B.V./Vekoma Manufacturing B.V.	97330
32024	Vekoma International B.V./Vekoma Manufacturing B.V.	97154
32025	Vekoma International B.V./Vekoma Manufacturing B.V.	97197
32026	Vekoma International B.V./Vekoma Manufacturing B.V.	97332
32027	Vekoma International B.V./Vekoma Manufacturing B.V.	97331
32028	Vekoma International B.V./Vekoma Manufacturing B.V.	97123
32029	Vekoma International B.V./Vekoma Manufacturing B.V.	98130
32030	Vekoma International B.V./Vekoma Manufacturing B.V.	99262

\* In the interests of safety and as a service to the industry, Vekoma Rides Parts & Services B.V. issues technical information bulletins for the benefit of owners of amusement rides that are manufactured by Vekoma Rides Manufacturing B.V. (both companies are members of the Vekoma Rides B.V.). These bulletins may also contain technical information, on parts or modifications relating to amusement rides, manufactured by *Vekoma International B.V.* and / or *Vekoma Manufacturing B.V.* These are dissolved companies which have no legal relationship whatsoever with the Vekoma Rides B.V.

Vekoma Rides B.V. including its affiliated companies, agents and employees make no warranties and assume no responsibility for any misapplication or misinterpretation of the information provided, ride down time, consequential damages, loss, injuries, causes of action, claims, demands and expenses (including legal fees), of any kind or nature, arising directly or indirectly, in whole or in part, from or in relation to this technical information bulletin; nor for any amusement ride equipment built by any manufacturer(s) other than Vekoma Rides Manufacturing B.V.

All information relating to amusement rides, parts or modifications built or carried out by manufacturers other than Vekoma Rides Manufacturing B.V. and/or marked with an asterisk "\*" are recommendations only and are not to be considered in any way to be advisory or mandatory, relied upon, nor imply any obligations or liabilities whatsoever.



Issuing Entity:	Bulletin No.: SB-002_04
Vekoma Rides Parts & Services B.V.	Release Date: 30-03-2016
Schaapweg 18	Effective Date: Immediately
6063 BA VLODROP	Supersedes: 2-SB-002-311006/ 1-SB-002-060214/ 2-SB002-170214
The Netherlands	Completion Date: 01-01-2017
CoC Number: 12049585	

IB-nr.	Original Ride Manufacturer	Project number
32031	Vekoma International B.V./Vekoma Manufacturing B.V.	98182
32032	Vekoma International B.V./Vekoma Manufacturing B.V.	99272
32033	Vekoma Rides Manufacturing B.V.	91000
32035	Vekoma Rides Manufacturing B.V.	91084
32036	Vekoma Rides Manufacturing B.V.	91004
32037	Vekoma Rides Manufacturing B.V.	91013
32038	Vekoma Rides Manufacturing B.V.	60007
32039	Vekoma Rides Manufacturing B.V.	60032
32040	Vekoma Rides Manufacturing B.V.	60158
32041	Vekoma Rides Manufacturing B.V.	60468
32042	Vekoma Rides Manufacturing B.V.	60617

Table 1: Affected serial Nos.

\* In the interests of safety and as a service to the industry, Vekoma Rides Parts & Services B.V. issues technical information bulletins for the benefit of owners of amusement rides that are manufactured by Vekoma Rides Manufacturing B.V. (both companies are members of the Vekoma Rides B.V.). These bulletins may also contain technical information, on parts or modifications relating to amusement rides, manufactured by *Vekoma International B.V.* and / or *Vekoma Manufacturing B.V.* These are dissolved companies which have no legal relationship whatsoever with the Vekoma Rides B.V.

Vekoma Rides B.V. including its affiliated companies, agents and employees make no warranties and assume no responsibility for any misapplication or misinterpretation of the information provided, ride down time, consequential damages, loss, injuries, causes of action, claims, demands and expenses (including legal fees), of any kind or nature, arising directly or indirectly, in whole or in part, from or in relation to this technical information bulletin; nor for any amusement ride equipment built by any manufacturer(s) other than Vekoma Rides Manufacturing B.V.

All information relating to amusement rides, parts or modifications built or carried out by manufacturers other than Vekoma Rides Manufacturing B.V. and/or marked with an asterisk "\*" are recommendations only and are not to be considered in any way to be advisory or mandatory, relied upon, nor imply any obligations or liabilities whatsoever.





Issuing Entity:	Bulletin No.: SB-002_04
Vekoma Rides Parts & Services B.V.	Release Date: 30-03-2016
Schaapweg 18	Effective Date: Immediately
6063 BA VLODROP	Supersedes: 2-SB-002-311006/ 1-SB-002-060214/ 2-SB002-170214
The Netherlands	Completion Date: 01-01-2017
CoC Number: 12049585	

Details of issue continued:

## 1.1 Assembly instructions main axle

### 1.1.1 Mounting procedure flange nut at upper side of the main axle

▼ **For the assembly of the vertical main axle spindle the following additional instructions have to be followed:**

- 1 Take care that the parts have to be assembled are clean, within tolerance and NDT tested.
- 2 Apply lubricant to the:  
(Refer to TS-L03 for the correct lubricants)
  - Inside of the pre-cleaned hole for the vertical spindle in the main beam.
  - Pre-cleaned thread of the vertical spindle as well as the pre-cleaned thread of the flange nut and flange.
  - Both sides of the pressure washer.
- 3 Mount the vertical spindle (figure 1/2) into the main beam (figure 1/1), take care to align the spindle face with the alignment rim on the main beam.

**Note:**

*If necessary the main beam may be heated 40 degrees above ambient temperature, or a small hand press may be used to put the spindle into the main beam.*

\* In the interests of safety and as a service to the industry, Vekoma Rides Parts & Services B.V. issues technical information bulletins for the benefit of owners of amusement rides that are manufactured by Vekoma Rides Manufacturing B.V. (both companies are members of the Vekoma Rides B.V.). These bulletins may also contain technical information, on parts or modifications relating to amusement rides, manufactured by Vekoma International B.V. and / or Vekoma Manufacturing B.V. These are dissolved companies which have no legal relationship whatsoever with the Vekoma Rides B.V.

Vekoma Rides B.V. including its affiliated companies, agents and employees make no warranties and assume no responsibility for any misapplication or misinterpretation of the information provided, ride down time, consequential damages, loss, injuries, causes of action, claims, demands and expenses (including legal fees), of any kind or nature, arising directly or indirectly, in whole or in part, from or in relation to this technical information bulletin; nor for any amusement ride equipment built by any manufacturer(s) other than Vekoma Rides Manufacturing B.V.

All information relating to amusement rides, parts or modifications built or carried out by manufacturers other than Vekoma Rides Manufacturing B.V. and/or marked with an asterisk "\*" are recommendations only and are not to be considered in any way to be advisory or mandatory, relied upon, nor imply any obligations or liabilities whatsoever.



**Make sure the spindle goes in straight. Otherwise the main beam surface will be damaged.**

- 4 Place the pressure washer (figure 1/3) and the flange nut (figure 1/4) over the vertical spindle.
- 5 Tighten the flange nut to 250 Nm using a calibrated torque wrench with proper socket.

Then make a first mark, see figure 2, which indicates the start point for the final tightening of the flange nut. Make a second mark, 120° further.

The final step is to tighten the flange nut. Turn the nut further over 120° (clockwise) in one smooth movement in order to achieve the required pre-tension.

- 6 Assemble all other parts as mentioned in the operation and maintenance manual.

\* In the interests of safety and as a service to the industry, Vekoma Rides Parts & Services B.V. issues technical information bulletins for the benefit of owners of amusement rides that are manufactured by Vekoma Rides Manufacturing B.V. (both companies are members of the Vekoma Rides B.V.). These bulletins may also contain technical information, on parts or modifications relating to amusement rides, manufactured by *Vekoma International B.V.* and / or *Vekoma Manufacturing B.V.* These are dissolved companies which have no legal relationship whatsoever with the Vekoma Rides B.V.

Vekoma Rides B.V. including its affiliated companies, agents and employees make no warranties and assume no responsibility for any misapplication or misinterpretation of the information provided, ride down time, consequential damages, loss, injuries, causes of action, claims, demands and expenses (including legal fees), of any kind or nature, arising directly or indirectly, in whole or in part, from or in relation to this technical information bulletin; nor for any amusement ride equipment built by any manufacturer(s) other than Vekoma Rides Manufacturing B.V.

All information relating to amusement rides, parts or modifications built or carried out by manufacturers other than Vekoma Rides Manufacturing B.V. and/or marked with an asterisk "\*" are recommendations only and are not to be considered in any way to be advisory or mandatory, relied upon, nor imply any obligations or liabilities whatsoever.

Details of issue continued:

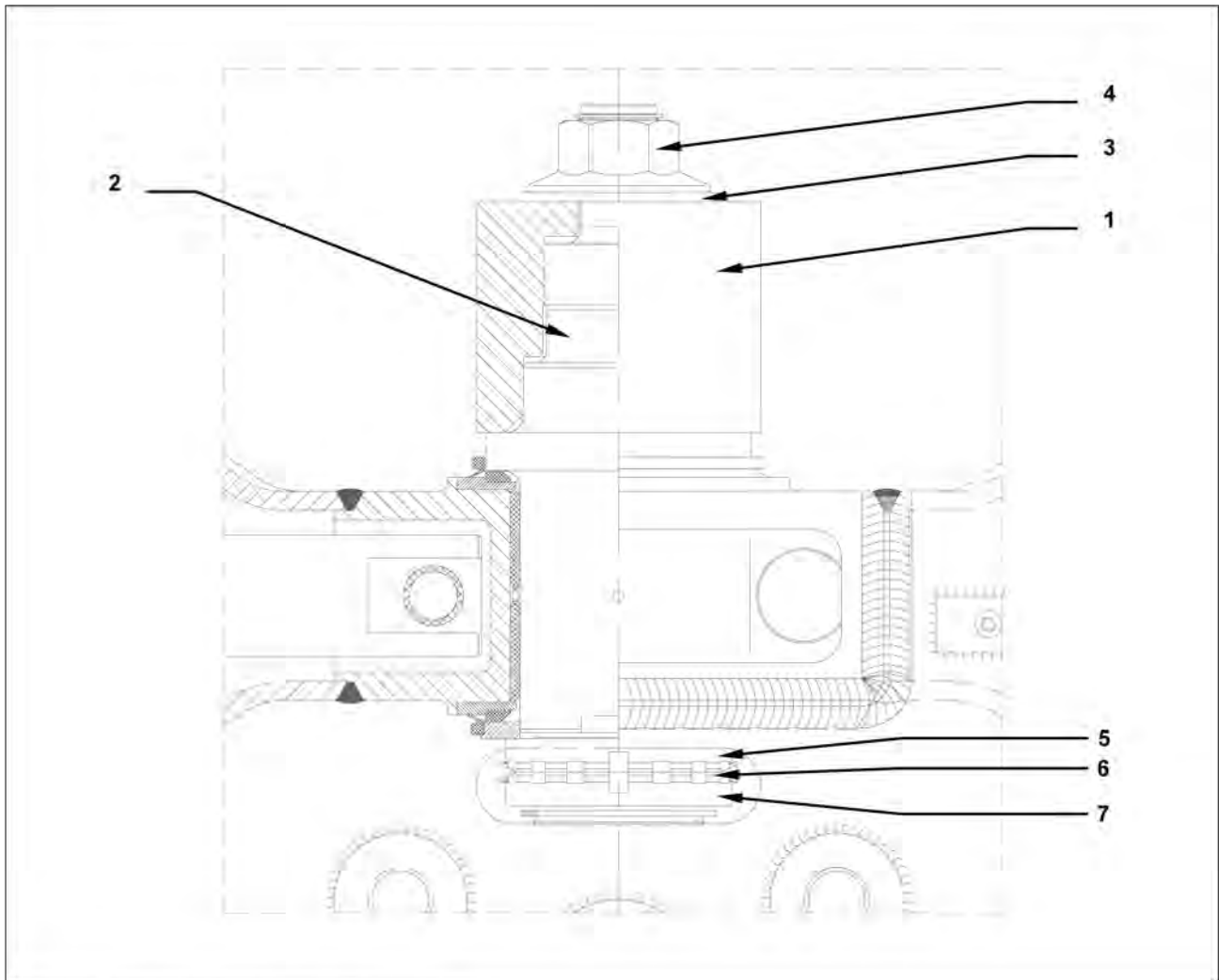

figure 1: Assembly vertical spindle main axle

\* In the interests of safety and as a service to the industry, Vekoma Rides Parts & Services B.V. issues technical information bulletins for the benefit of owners of amusement rides that are manufactured by Vekoma Rides Manufacturing B.V. (both companies are members of the Vekoma Rides B.V.). These bulletins may also contain technical information, on parts or modifications relating to amusement rides, manufactured by *Vekoma International B.V.* and / or *Vekoma Manufacturing B.V.* These are dissolved companies which have no legal relationship whatsoever with the Vekoma Rides B.V.

Vekoma Rides B.V. including its affiliated companies, agents and employees make no warranties and assume no responsibility for any misapplication or misinterpretation of the information provided, ride down time, consequential damages, loss, injuries, causes of action, claims, demands and expenses (including legal fees), of any kind or nature, arising directly or indirectly, in whole or in part, from or in relation to this technical information bulletin, nor for any amusement ride equipment built by any manufacturer(s) other than Vekoma Rides Manufacturing B.V.

All information relating to amusement rides, parts or modifications built or carried out by manufacturers other than Vekoma Rides Manufacturing B.V. and/or marked with an asterisk "\*" are recommendations only and are not to be considered in any way to be advisory or mandatory, relied upon, nor imply any obligations or liabilities whatsoever.



Details of issue continued:

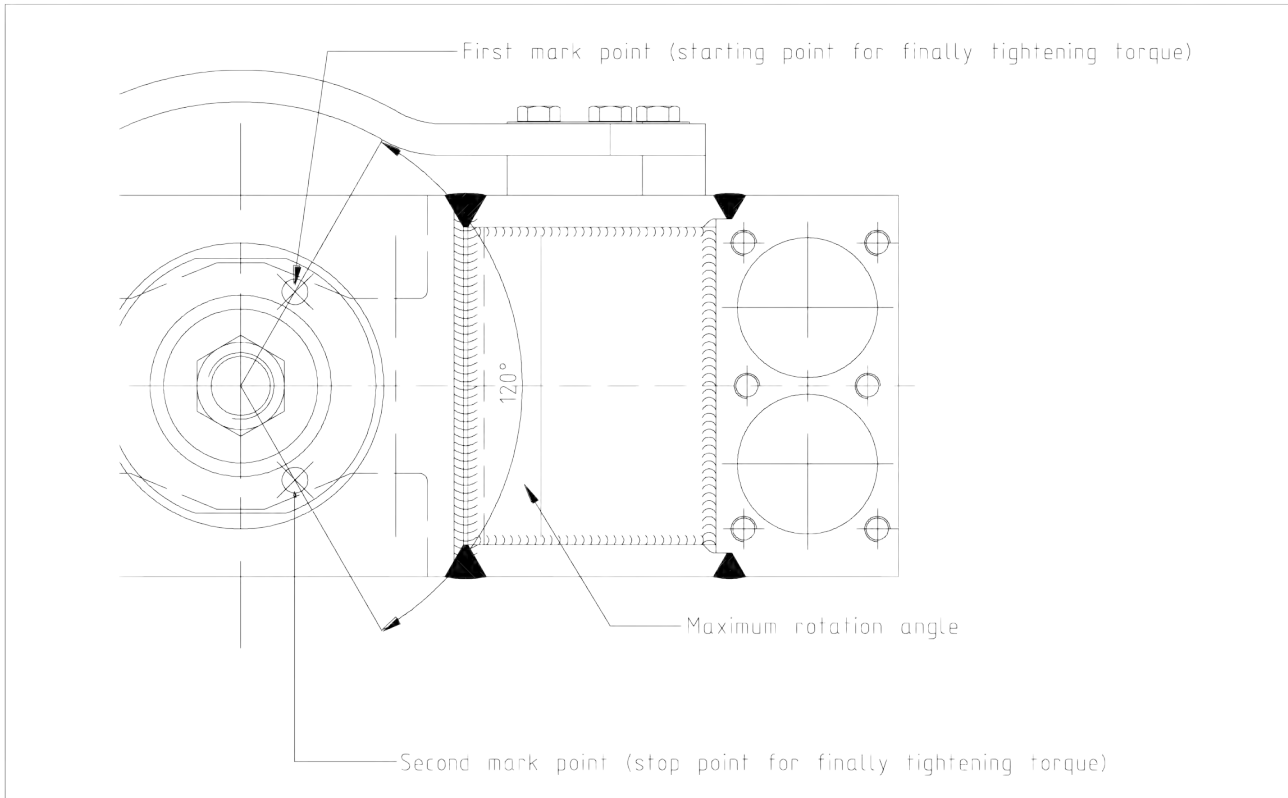

figure 2: Tightening flange nut

\* In the interests of safety and as a service to the industry, Vekoma Rides Parts & Services B.V. issues technical information bulletins for the benefit of owners of amusement rides that are manufactured by Vekoma Rides Manufacturing B.V. (both companies are members of the Vekoma Rides B.V.). These bulletins may also contain technical information, on parts or modifications relating to amusement rides, manufactured by *Vekoma International B.V.* and / or *Vekoma Manufacturing B.V.* These are dissolved companies which have no legal relationship whatsoever with the Vekoma Rides B.V.

Vekoma Rides B.V. including its affiliated companies, agents and employees make no warranties and assume no responsibility for any misapplication or misinterpretation of the information provided, ride down time, consequential damages, loss, injuries, causes of action, claims, demands and expenses (including legal fees), of any kind or nature, arising directly or indirectly, in whole or in part, from or in relation to this technical information bulletin, nor for any amusement ride equipment built by any manufacturer(s) other than Vekoma Rides Manufacturing B.V.

All information relating to amusement rides, parts or modifications built or carried out by manufacturers other than Vekoma Rides Manufacturing B.V. and/or marked with an asterisk "\*" are recommendations only and are not to be considered in any way to be advisory or mandatory, relied upon, nor imply any obligations or liabilities whatsoever.



Issuing Entity:	Bulletin No.: SB-002_04
Vekoma Rides Parts & Services B.V.	Release Date: 30-03-2016
Schaapweg 18	Effective Date: Immediately
6063 BA VLODROP	Supersedes: 2-SB-002-311006/ 1-SB-002-060214/ 2-SB002-170214
The Netherlands	Completion Date: 01-01-2017
CoC Number: 12049585	

Details of issue continued:

## 1.1.2 Mounting procedure locking nuts at the lower side of the main axle

### ▼ Proceed as follows:

- 1 Apply lubricant to the:  
(Refer to TS-L03 for the correct lubricants)
  - Pre-cleaned thread of the vertical spindle as well as the pre-cleaned thread of the locking nut.
  - Both sides of both locking washers.
- 2 Torque the first locking nut (figure 1/5) to 200 Nm using proper tools (SKF).  
By this action, all axial play will be removed.
- 3 Loosen the first locking nut and finally torque it to 100 Nm using proper tools (SKF).
- 4 Reinstall new locking plates (figure 1/6).
- 5 Torque the second locking nut (figure 1/7) to 150 Nm using proper tools (SKF), while holding the first locking nut.
- 6 Check if the locking plates did not rotate after applying torque to the second locking nut. Otherwise the internal tab could be damaged and needs to be replaced
- 7 Lock the locking plates with a tab into the locking nut. Do not damage the locking nut.

### Notes:

*Always use the correct tools for assembling the locking nuts.*

*Check the locking nuts for damage and cracks. In case of cracks or other damages the locking nuts must be replaced by new locking nuts.*

*Locking plates may only be used once.*

\* In the interests of safety and as a service to the industry, Vekoma Rides Parts & Services B.V. issues technical information bulletins for the benefit of owners of amusement rides that are manufactured by Vekoma Rides Manufacturing B.V. (both companies are members of the Vekoma Rides B.V.). These bulletins may also contain technical information, on parts or modifications relating to amusement rides, manufactured by *Vekoma International B.V.* and / or *Vekoma Manufacturing B.V.* These are dissolved companies which have no legal relationship whatsoever with the Vekoma Rides B.V.

Vekoma Rides B.V. including its affiliated companies, agents and employees make no warranties and assume no responsibility for any misapplication or misinterpretation of the information provided, ride down time, consequential damages, loss, injuries, causes of action, claims, demands and expenses (including legal fees), of any kind or nature, arising directly or indirectly, in whole or in part, from or in relation to this technical information bulletin; nor for any amusement ride equipment built by any manufacturer(s) other than Vekoma Rides Manufacturing B.V.

All information relating to amusement rides, parts or modifications built or carried out by manufacturers other than Vekoma Rides Manufacturing B.V. and/or marked with an asterisk "\*" are recommendations only and are not to be considered in any way to be advisory or mandatory, relied upon, nor imply any obligations or liabilities whatsoever.

## 2 Spindle failure during disassembly

During disassembly of the vertical spindle with article number 3009834 a spindle failed at one of our customers. The spindle in question failed at the location just below the thread of the flange nut on top of the main axle (see figure 3) It is suspected that the failure occurred due to incorrect disassembly of the flange nut (01201-52-2155 with article number 3008526) leading to a torsional overload. Further investigation to the root cause of the failure is still ongoing.

While the investigation is still ongoing more detailed maintenance instructions are required.



**Pay extra attention to this particular connection (for loose nut with stub) during daily inspection.**

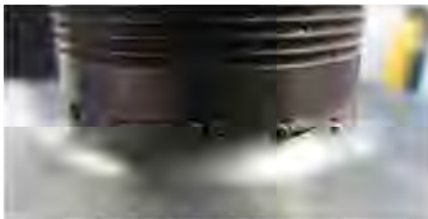

**Figure 3: Spindle failure**

\* In the interests of safety and as a service to the industry, Vekoma Rides Parts & Services B.V. issues technical information bulletins for the benefit of owners of amusement rides that are manufactured by Vekoma Rides Manufacturing B.V. (both companies are members of the Vekoma Rides B.V.). These bulletins may also contain technical information, on parts or modifications relating to amusement rides, manufactured by *Vekoma International B.V.* and / or *Vekoma Manufacturing B.V.* These are dissolved companies which have no legal relationship whatsoever with the Vekoma Rides B.V.

Vekoma Rides B.V. including its affiliated companies, agents and employees make no warranties and assume no responsibility for any misapplication or misinterpretation of the information provided, ride down time, consequential damages, loss, injuries, causes of action, claims, demands and expenses (including legal fees), of any kind or nature, arising directly or indirectly, in whole or in part, from or in relation to this technical information bulletin, nor for any amusement ride equipment built by any manufacturer(s) other than Vekoma Rides Manufacturing B.V.

All information relating to amusement rides, parts or modifications built or carried out by manufacturers other than Vekoma Rides Manufacturing B.V. and/or marked with an asterisk "\*" are recommendations only and are not to be considered in any way to be advisory or mandatory, relied upon, nor imply any obligations or liabilities whatsoever.