



**CHANCE RIDES MANUFACTURING, INC.**  
**4200 Walker**  
**Wichita, KS 67277-2328**  
**U.S.A.**  
Phone: 1-316-942-7411 • FAX: 1-316-942-2012  
**Website: [www.chancerides.com](http://www.chancerides.com)**  
**E-mail: [rides@chancerides.com](mailto:rides@chancerides.com)**

Bulletin No:	B418CRM202-B
Release Date:	August 1, 2017
Effective Date:	August 1, 2017
Supersedes:	A418CRM202-A
Completion Date:	See Text
Page:	1 of 3

# SERVICE BULLETIN

Manufacturer: CHANCE RIDES MANUFACTURING, INC., CHANCE MORGAN INC.

Affected Production Dates: All

Ride Name: REVOLUTION 32 and REVOLUTION 20

Affected Serial Nos.: All

Model No.: 418 and 422

Abstract of Issue:

Inspection of Vehicle Frame

Reason For Release:

**This service bulletin supersedes Safety Alert A418CRM202-A. It is no longer in effect and should be discarded.**

Chance Rides, Inc. has become aware of a vehicle frame failure on the KMG Fireball, which is a 24-passenger portable ride. The Chance REVOLUTION 32 and REVOLUTION 20 share some features with the KMG Fireball, but the Chance products were designed as park model rides. Significant differences between the Chance REVOLUTION and KMG Fireball include the vehicle attachment area, which is of a different design.

Failure of the vehicle frame can result in serious personal injury to passengers and/or bystanders. Chance Rides Manufacturing, Inc. has performed additional analysis and field inspection on REVOLUTION 20 and REVOLUTION 32 rides, and has reviewed feedback from owners of these rides. We have determined that the vehicle frame presents no safety risk when maintained and inspected per the our specifications.

This bulletin is being issued to revise the previously published inspection interval. A detailed inspection procedure is provided to verify the integrity of the vehicle frames and ensure the safety of these rides.

Action to be Taken:

All owners of the above noted REVOLUTION 32 and REVOLUTION 20 amusement rides are required to perform the inspection described in this service bulletin annually.

- **If any indications are found**, contact Chance Rides Manufacturing immediately. DO NOT OPERATE THE RIDE.
- **If no indications are found**, the ride can operated normally.

All work must be performed by qualified personnel, capable of understanding the function of the parts and their proper installation. Use only those components authorized, specified or provided by Chance Rides Manufacturing, Inc. All applicable OSHA safety standards and safe industry practices must be observed.

Observe all safety information contained in the manufacturer's manuals. Make available this bulletin and all related technical information to personnel using the equipment.



**CHANCE RIDES MANUFACTURING, INC.**  
**4200 Walker**  
**Wichita, KS 67277-2328**  
**U.S.A.**  
Phone: 1-316-942-7411 • FAX: 1-316-942-2012  
**Website: [www.chancerides.com](http://www.chancerides.com)**  
**E-mail: [rides@chancerides.com](mailto:rides@chancerides.com)**

Bulletin No:	B418CRM202-B
Release Date:	August 1, 2017
Effective Date:	August 1, 2017
Supersedes:	A418CRM202-A
Completion Date:	See Text
Page:	2 of 3

Ride Manufacturer: CHANCE RIDES MANUFACTURING, INC., CHANCE MORGAN INC. Affected Production Dates: All

Ride Name: REVOLUTION 32 and REVOLUTION 20 Affected Serial Nos.: All

Model No.: 418 and 422

Detail of Issue

### **Inspection Procedure**

Visually inspect every vehicle in the areas detailed in the following illustrations. Look for cracks in the welds and in the parent metal near the welds.

- **If any indications are found, do not attempt to repair.** Contact Chance Rides Manufacturing, Inc. immediately. **DO NOT OPERATE THE RIDE.**
- **If no indications are found,** the ride can be operated normally. Repeat the visual inspections annually.

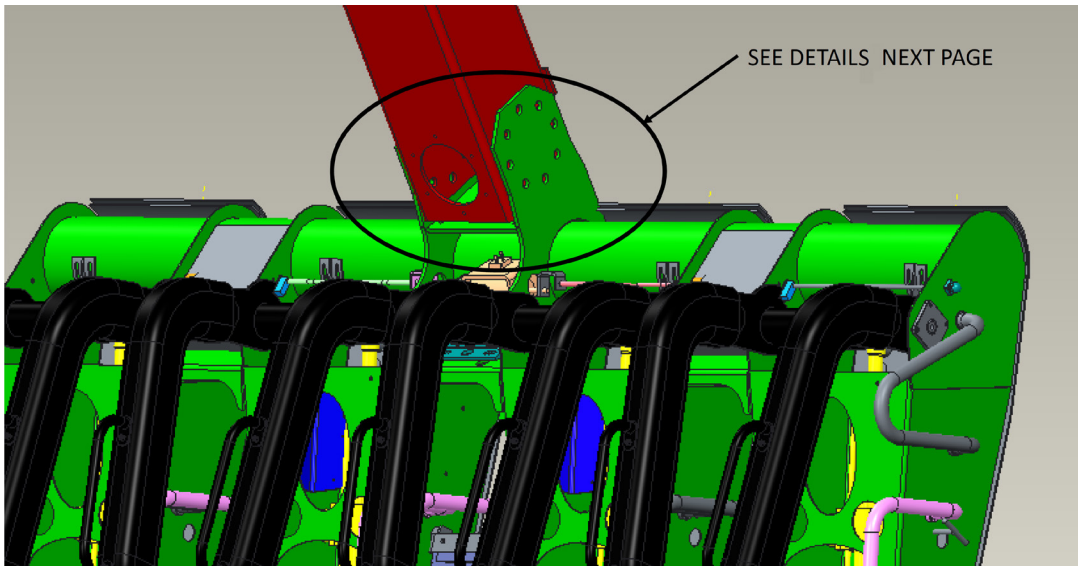

Chance Rides Manufacturing, Inc. issues notifications for the benefit of owners of amusement rides manufactured by Chance Rides Manufacturing, Inc. As a service to the industry, and in the interest of employee and public safety, Chance Rides Manufacturing, Inc. also issues notifications for the benefit of owners of amusement ride equipment for which the manufacturer no longer exists, such as the Allan Herschell Company, Chance Manufacturing Co., Inc., Chance Morgan, Inc., etc. In doing so, Chance Rides Manufacturing, Inc. does not assume liability for losses associated with amusement ride equipment built by manufacturers other than Chance Rides Manufacturing, Inc.



**CHANCE RIDES MANUFACTURING, INC.**  
4200 Walker  
Wichita, KS 67277-2328  
U.S.A.  
Phone: 1-316-942-7411 • FAX: 1-316-942-2012  
Website: [www.chancerides.com](http://www.chancerides.com)  
E-mail: [rides@chancerides.com](mailto:rides@chancerides.com)

Bulletin No:	B418CRM202-B
Release Date:	August 1, 2017
Effective Date:	August 1, 2017
Supersedes:	A418CRM202-A
Completion Date:	See Text
Page:	3 of 3

Ride Manufacturer: CHANCE RIDES MANUFACTURING, INC., CHANCE MORGAN INC. Affected Production Dates: All

Ride Name: REVOLUTION 32 and REVOLUTION 20 Affected Serial Nos.: All

Model No.: 418 and 422

Detail of Issue (continued):

*Visually inspect the joint between the round tube and the mounting ear*

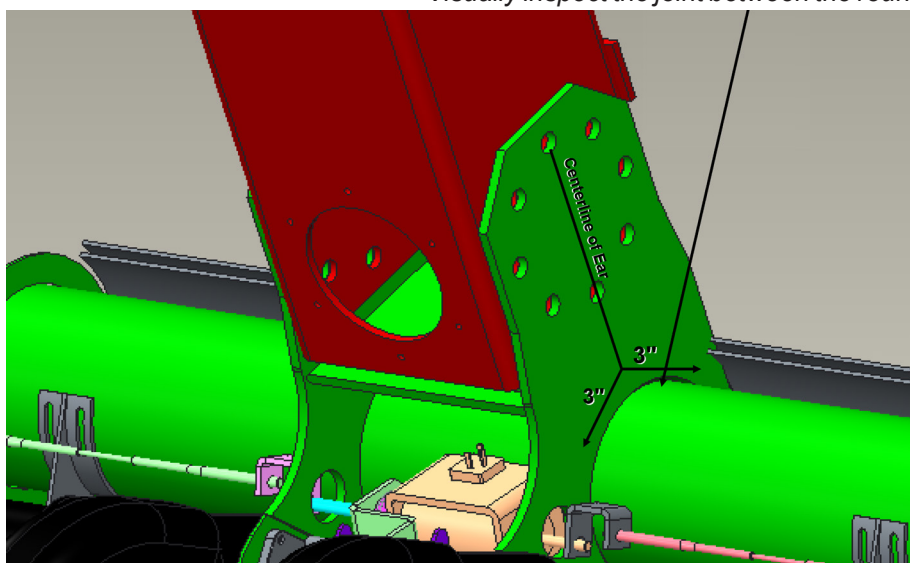

*Inspect approximately 3" out from the centerline of the ear as shown.*

*Inspect the same area on the outboard side of each ear on every vehicle.*

*Repeat this inspection annually.*

*Visually inspect the joint where the plate attaches to each mounting ear*

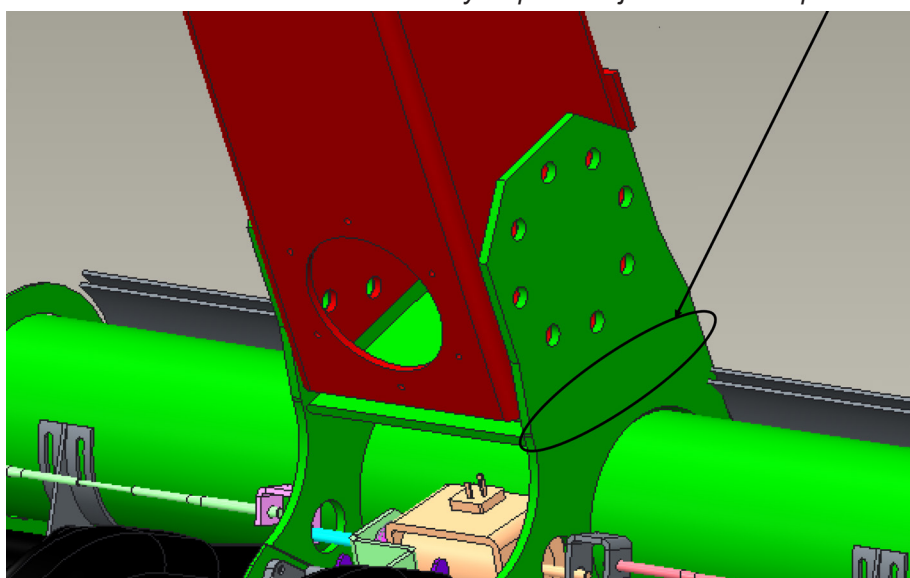

*From between the ears, inspect the top and bottom of the joint at both ends of the plate. Pay particular attention to the corners at the front and back edge of the plate.*

*Inspect the same area on every vehicle.*

*Repeat this inspection annually.*