

493.

Zamperla Samba Balloon gondola shaft cracking on older rides

NAFLIC has been made aware of a service bulletin (as attached) put out in 2019 by A.Zamperla SpA relating to the company's Samba Balloon rides.

Specifically, the bulletin refers to such devices that are over 20 years old and the fact that cracks have been noted on some examples on the gondola shafts. The bulletin includes a number of recommendations for this issue, including the performing of NDT as per the accompanying schedule and the replacement of various parts.

The information contained within is that of the manufacturer and not NAFLIC. When following the advice from the manufacturer, you are reminded of your duties and responsibilities under HSG175 regarding modifications.

Ride distributed by:
Zamperla Spa
36077 Altavilla Vicentina
via Mte Grappa 15/17

ITALY
Phone: +39 0444 998400
Fax: +39 0444 573720
e-mail: zamperla@zamperla.it



Bulletin No: SB-01-2018
Release Date: December 1, 2018
Effective Date: January 1, 2019
Supersedes:
Completion Date: Before 2019 operating season.

Page: 1 of 33

SERVICE BULLETIN

Ride Manufacturer: A. Zamperla SpA	Affected Production Dates: 2015 and earlier
Ride Name: Samba Balloon	Affected Serial Nos.:
Model Number: Samba Balloon - all	All

Abstract Of Issue:

Align older rides with most current non-destructive testing (NDT) and replacement schedule.

Reason For Release:

Cracks noted on gondola shafts on rides older than 20 years.

Action To Be Taken:

Perform NDT as per the attached schedule. Replace parts as per attached schedule. The items reported on the REPLACEMENT SCHEDULE may be used for the 2019 operating season only if the NDT defined for that part is performed and passes.

Shaft pins, truss arm pins, wheel trolley support pins and hydraulic cylinder pins (items 3,11,15,16) that are 10 years or older must be replaced for the 2020 season regardless of testing performed.

Gondola shafts (items 2) that are 20 years or older, must be replaced for the 2020 season regardless of testing performed.

Detail Of Issue:

Perform NDT as per the attached schedule. Replace parts as per attached schedule. Base frames (image 18, 19 & 20) will vary based on the model and production year. Follow image that fits your model. Note, not all items may be shown for clarity.

Future Action To Be Taken:

Perform NDT as per the attached schedule and attached acceptance criteria. Replace parts as per attached schedule.

Include this bulletin with all maintenance documents.

SAMBA BALLOON – NDT & REPLACEMENT SCHEDULE

NDT SCHEDULE

Item	Drawing #	Component and Location	Image #	Test method code	Test every (Time Code)	Remarks
1		GONDOLA FRAME	1	VT	M6	Check welds
				MT	Y4	Check for cracks, corrosion
2		GONDOLA SHAFT	2	VT	M6	Check for cracks, corrosion, ovalization at pin holes
				MT	Y4	
3		SHAFT PIN	3	MT	Y4	Check for cracks
				UT	Y4	Check for corrosion
4.1		SHAFT SUPPORT (weld)	4	VT	M6	Check welds
				MT	Y4	Check for cracks, corrosion
4.2				VT	M6	Check welds
				MT	Y4	Check for cracks, corrosion
4.4		SHAFT SUPPORT (holes and tube)		MT	Y4	Check for cracks, corrosion, ovalization at pin holes
5		SUPPORT PIN	5	MT	Y4	Check for cracks
				UT	Y4	Check for corrosion
6.1		TRUSS ARM	6	VT	M6	Check welds
				MT	Y4	Check for cracks, corrosion
6.2				VT	M6	Check welds
				MT	Y4	Check for cracks, corrosion
6.3				VT	Y4	Check welds
				MT	Y4	Check welds
7		CROSS BAR	7	VT	M6	Check welds
				MT	Y4	Check for cracks, corrosion
8		TIE ROD	8	VT	M6	Check welds
				MT	Y4	Check for cracks, corrosion
9		CROSS BAR PIN	9	MT	Y4	Check welds
				UT	Y4	Check for cracks, corrosion
10		TIE ROD PIN	10	VT	M6	Check for cracks, corrosion
				MT	Y4	Check for cracks
11		TRUSS ARM PIN	11	UT	Y4	Check for corrosion
				MT	Y4	Check for cracks
12.1		ROTATING CENTER	12	VT	M6	Check welds
				MT	Y4	Check for cracks, corrosion
12.2				VT	M6	Check welds
				MT	Y4	Check for cracks, corrosion
12.3				VT	M6	Check welds
				MT	Y4	Check for cracks, corrosion
12.4				VT	M6	Check welds
				MT	Y4	Check for cracks, corrosion
12.5				VT	M6	Check welds
				MT	Y4	Check for cracks, corrosion
13.1		FIXED CENTER	13	VT	M6	Check welds
				MT	Y4	Check for cracks, corrosion
13.2				VT	M6	Check welds
				MT	Y4	Check for cracks, corrosion
13.3				VT	M6	Check welds
				MT	Y4	Check for cracks, corrosion
13.4				VT	M6	Check welds
				MT	Y4	Check for cracks, corrosion
13.5				VT	M6	Check welds
				MT	Y4	Check for cracks, corrosion
14		WHEEL TROLLEY	14	MT	Y8	Check for cracks
				UT	Y8	Check for corrosion
15		WHEEL TROLLEY SUPPORT PIN	15	MT	Y4	Check for cracks
				UT	Y4	Check for corrosion
16		HYDRAULIC CYLINDER PIN	16	MT	Y4	Check for cracks
				UT	Y4	Check for corrosion
17		COLUMN	17	VT	M6	Check welds
				MT	Y4	Check for cracks, corrosion
18.1		BASE FRAME PARK MODEL (NEW DESIGN)	18	VT	M6	Check welds
				MT	Y4	Check for cracks, corrosion
18.2				VT	M6	Check welds
				MT	Y4	Check for cracks, corrosion
19.1		BASE FRAME PARK MODEL (OLD DESIGN)	19	VT	M6	Check welds
				MT	Y4	Check for cracks, corrosion
19.2				VT	M6	Check welds
				MT	Y4	Check for cracks, corrosion
20.1		BASE FRAME TRAILER MODEL	20	VT	M6	Check welds
				MT	Y4	Check for cracks, corrosion
20.2				VT	M6	Check welds
				MT	Y4	Check for cracks, corrosion

SAMBA BALLOON – NDT & Replacement Schedule Rev.3

<p>Time Code</p> <p>M6 = every 6 months</p> <p>Y4 = every 4 years</p> <p>Y8 = every 8 years</p>	<p>Test Method Code</p> <p>VT = visual inspection (by certified inspector or maintenance mechanic)</p> <p>MT = magnetic particle testing procedure per (UNI EN ISO 17638 (2010)-23278 (2015) lev. 2X or ASTM E709.</p> <p>Acceptance per SB-01-2018 ZAMPERLA NDT TEST ACCEPTANCE CRITERIA.</p> <p>PT = dye penetrant testing procedure per (EN 571-1 / EN 1289-2X) or ASTM E165.</p> <p>Acceptance per SB-01-2018 ZAMPERLA NDT TEST ACCEPTANCE CRITERIA.</p> <p>UT = ultrasonic testing procedure per (EN 10308 (2004) CLASS 4) or per AWS D1.1 section 6.14.3.</p> <p>Acceptance per SB-01-2018 ZAMPERLA NDT TEST ACCEPTANCE CRITERIA.</p>
---	--

REPLACEMENT SCHEDULE

Item	Part #	Item	Replacement after [no. of years]
2		GONDOLA SHAFT	20
3		SHAFT PIN	10
11		TRUSS ARM PIN	10
15		WHEEL TROLLEY SUPPORT PIN	10
16		HYDRAULIC CYLINDER PIN	10

Please, contact Zamperla Spare Parts Department with ride serial number to get correct part number.

IMAGE 1 – GONDOLA FRAME

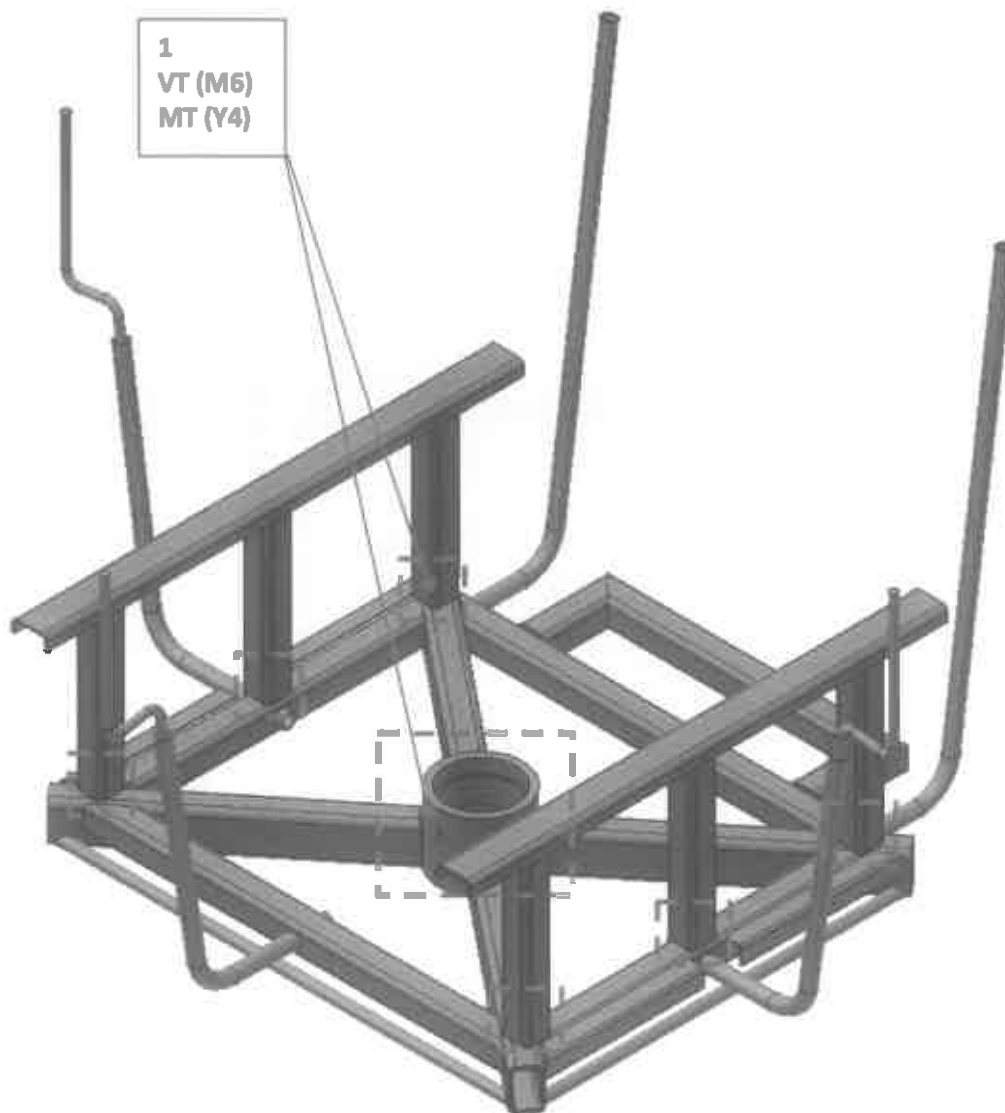

IMAGE 2 – GONDOLA SHAFT

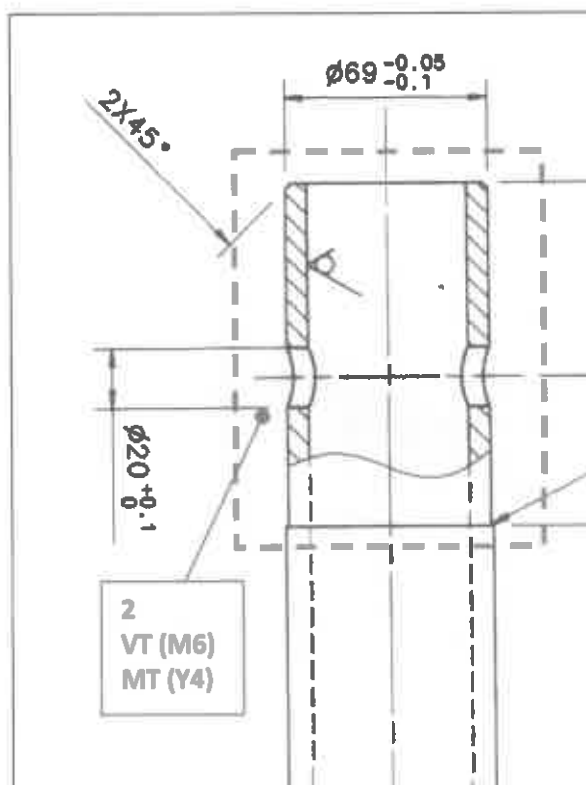

IMAGE 3 – SHAFT PIN

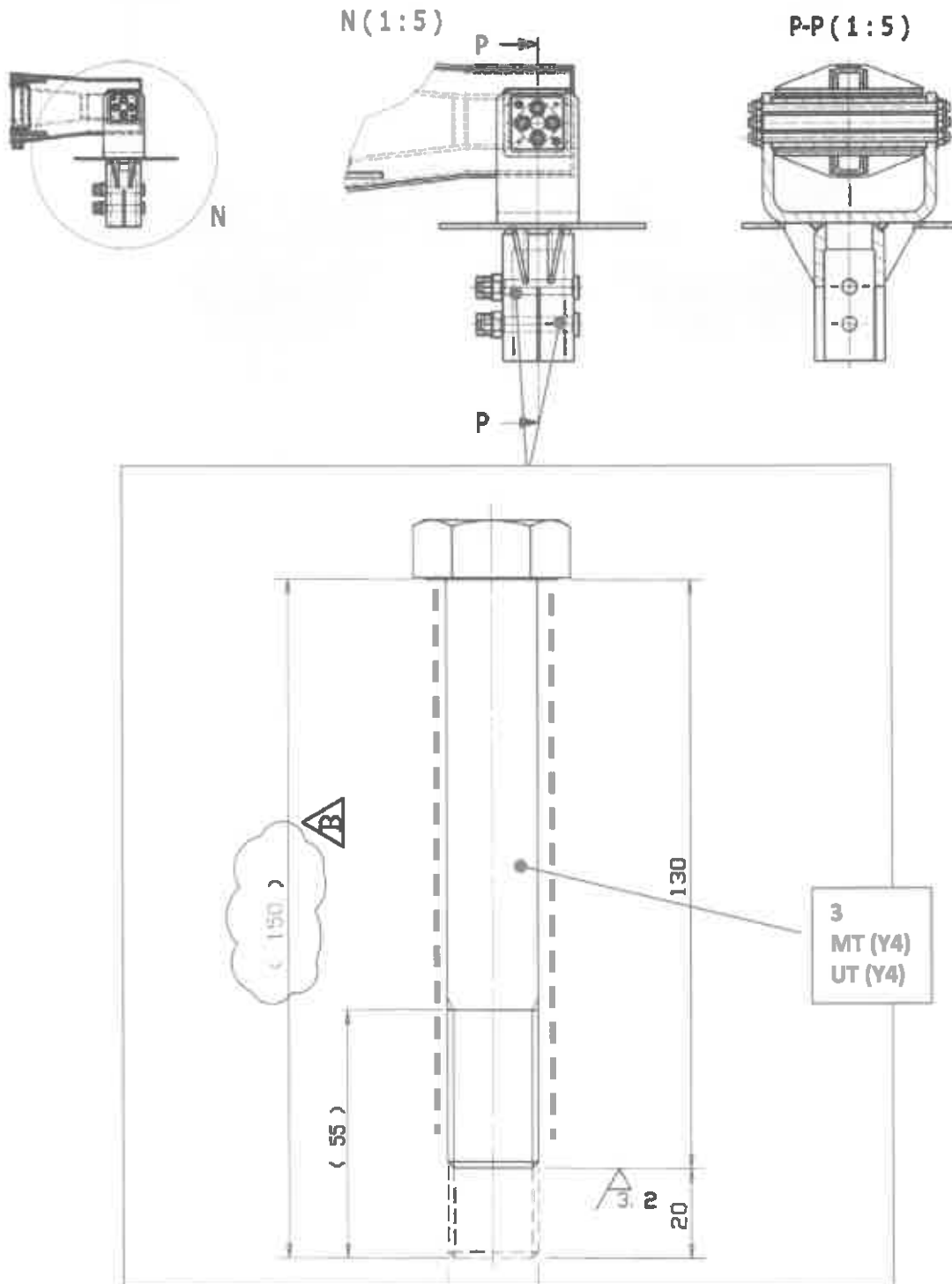

IMAGE 4 – SHAFT SUPPORT

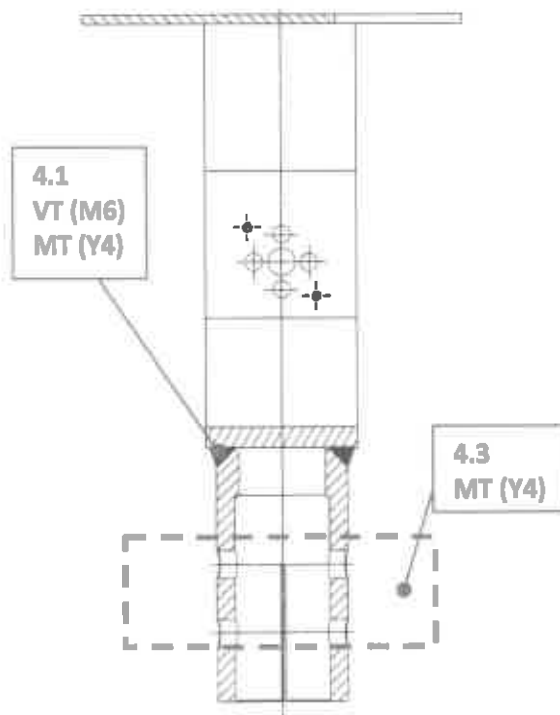

Image 4 – Shaft Support (continuation)

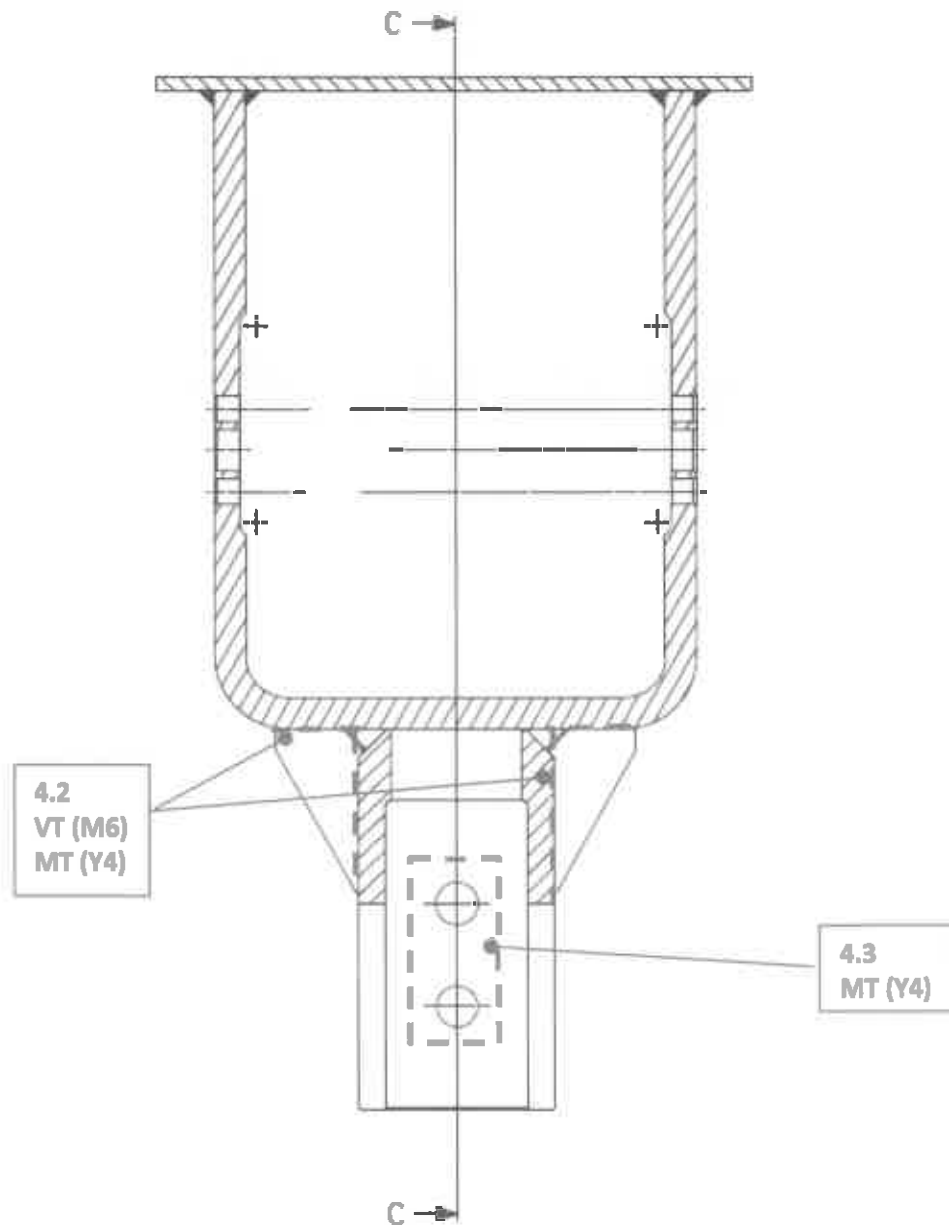

IMAGE 5 – SUPPORT PIN

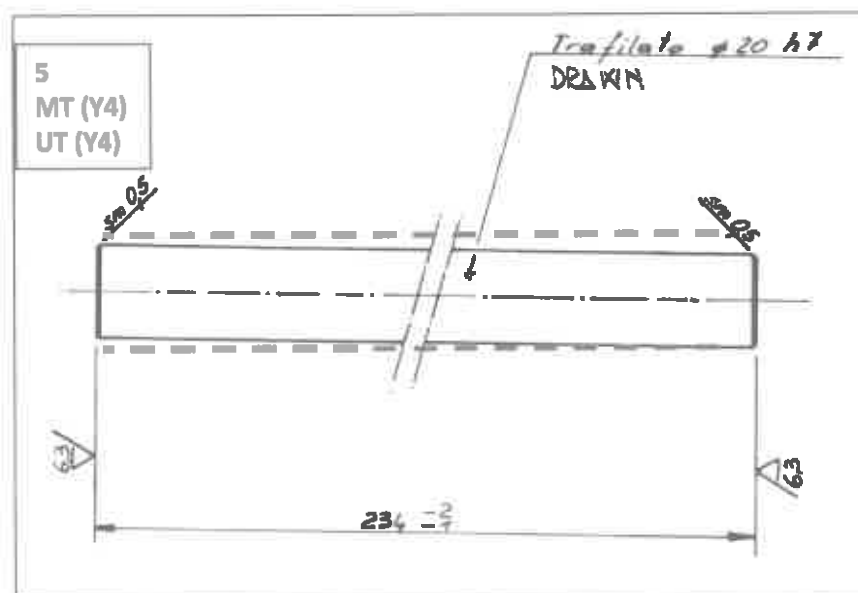
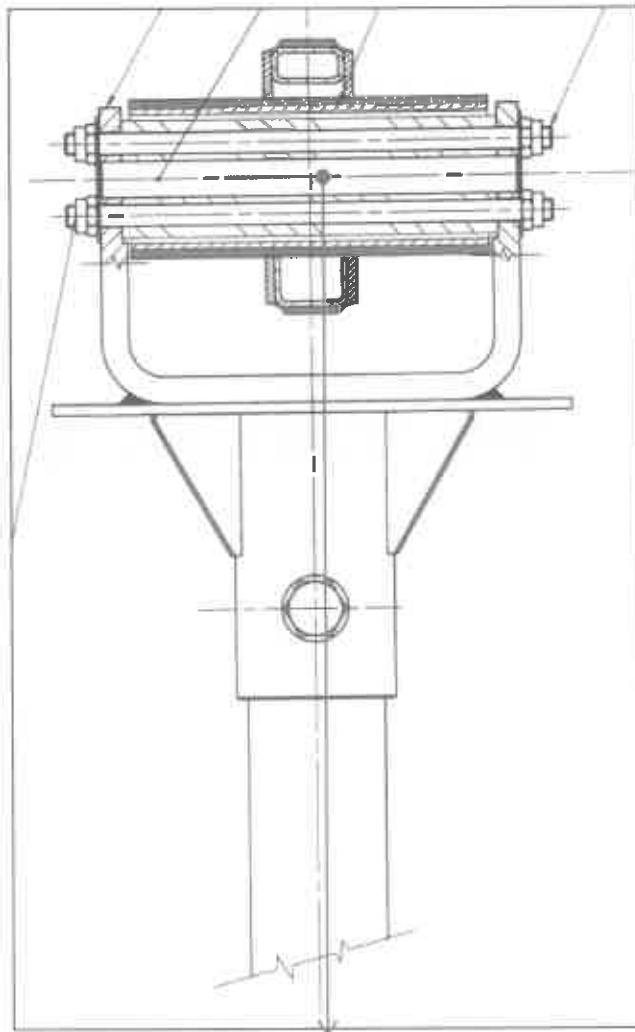
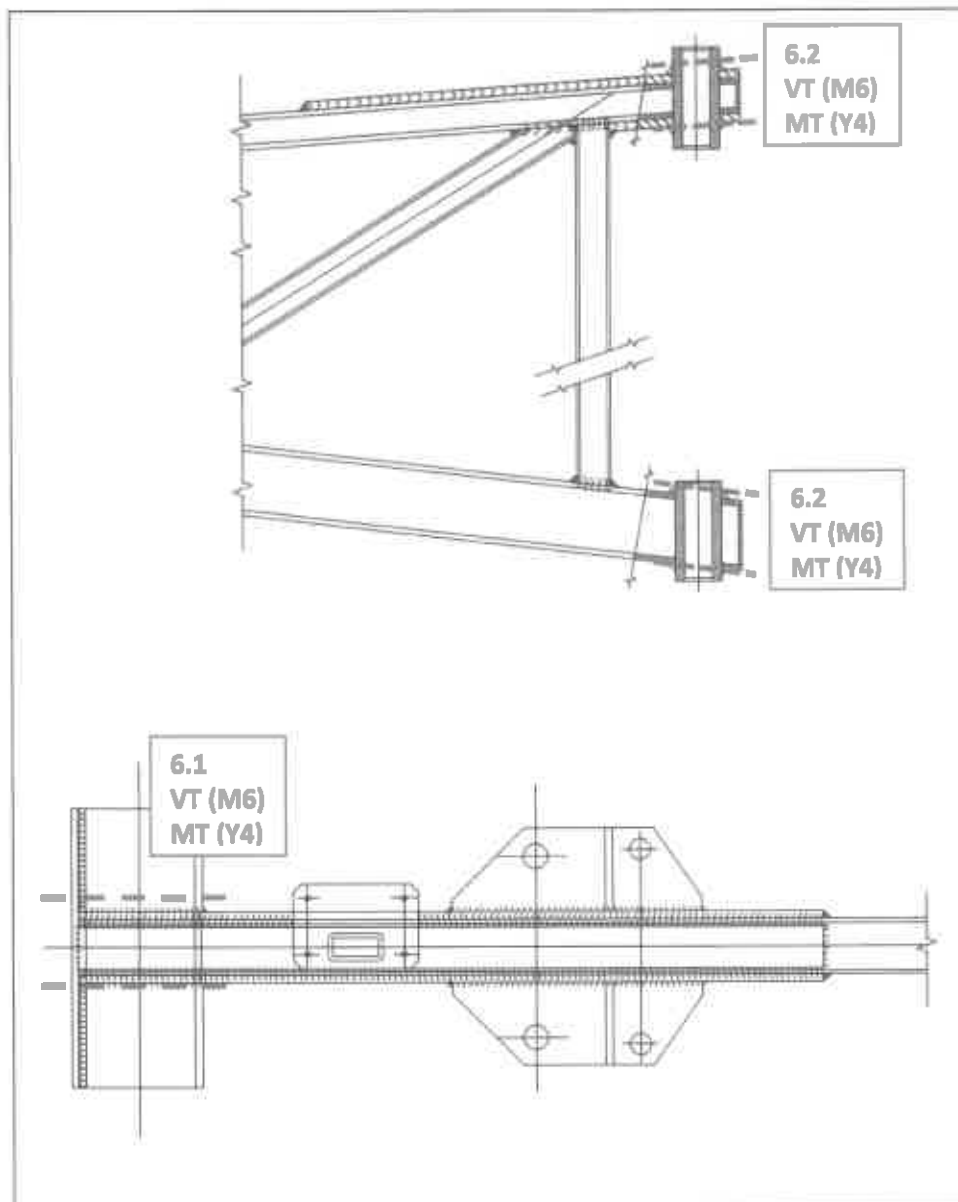
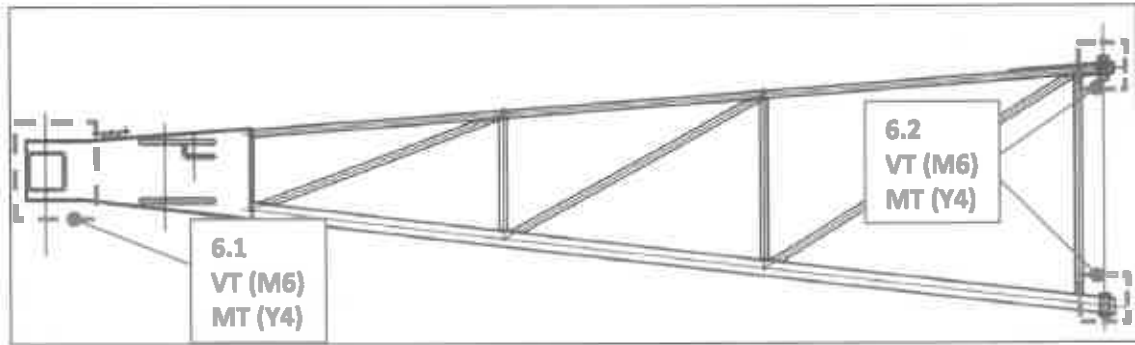
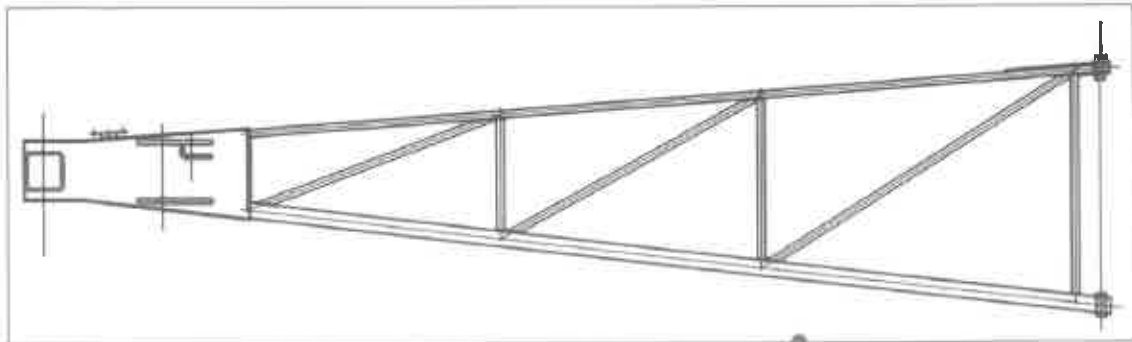

IMAGE 6 - TRUSS ARM



SAMBA BALLOON – NDT & Replacement Schedule Rev.3
Image 6 – Truss Arm (continuation)



6.3
VT (Y4)

IMAGE 7 – CROSS BAR

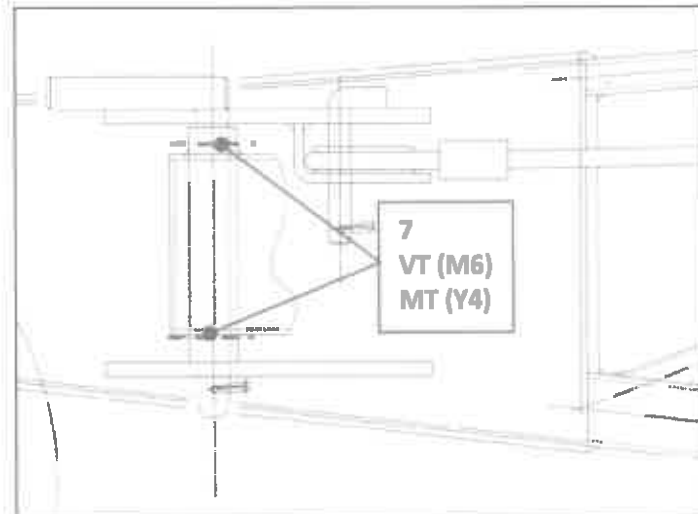
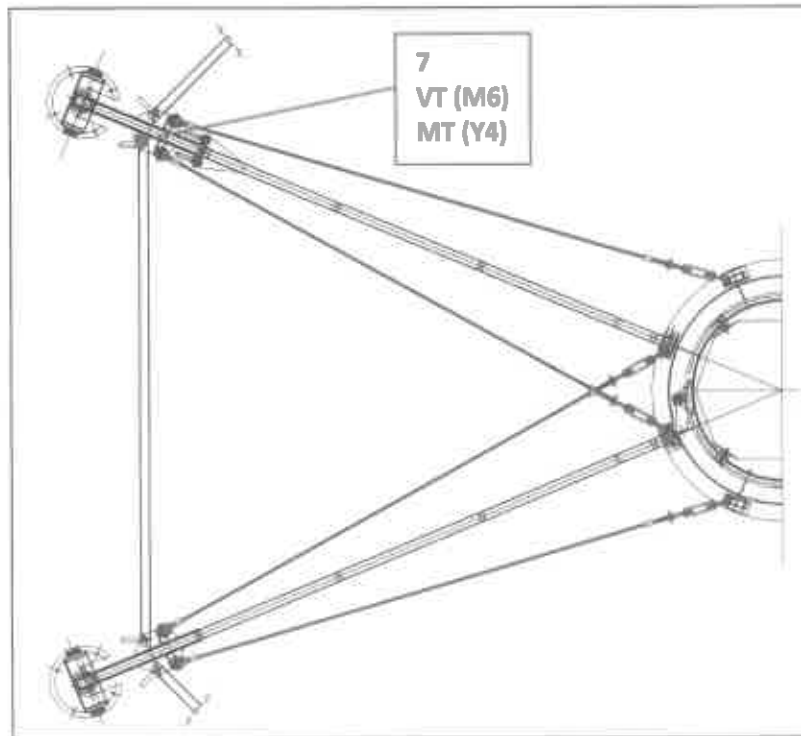

SAMBA BALLOON – NDT & Replacement Schedule Rev.3
Image 7 – Rim Beam (continuation)

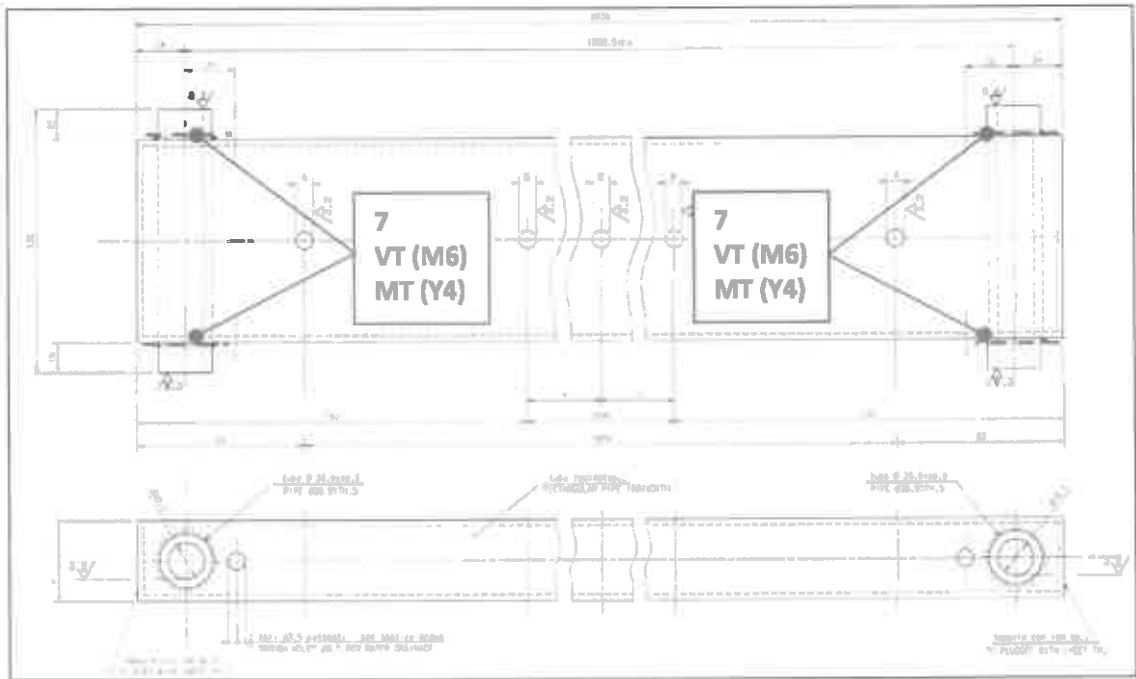

IMAGE 8 – TIE ROD

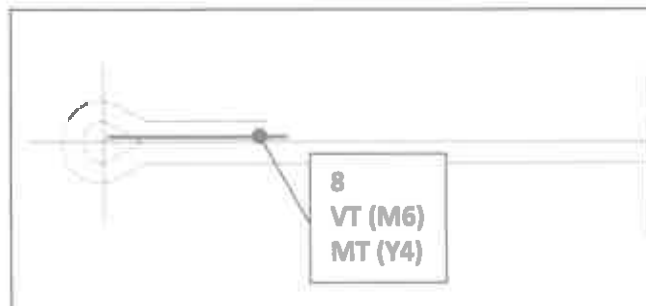
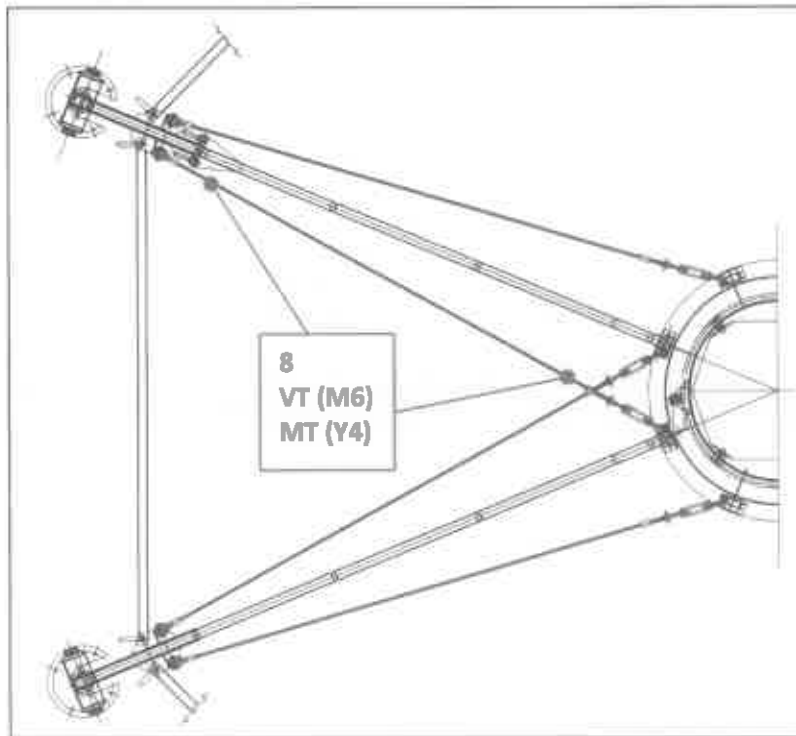

IMAGE 9 – CROSS BAR PIN

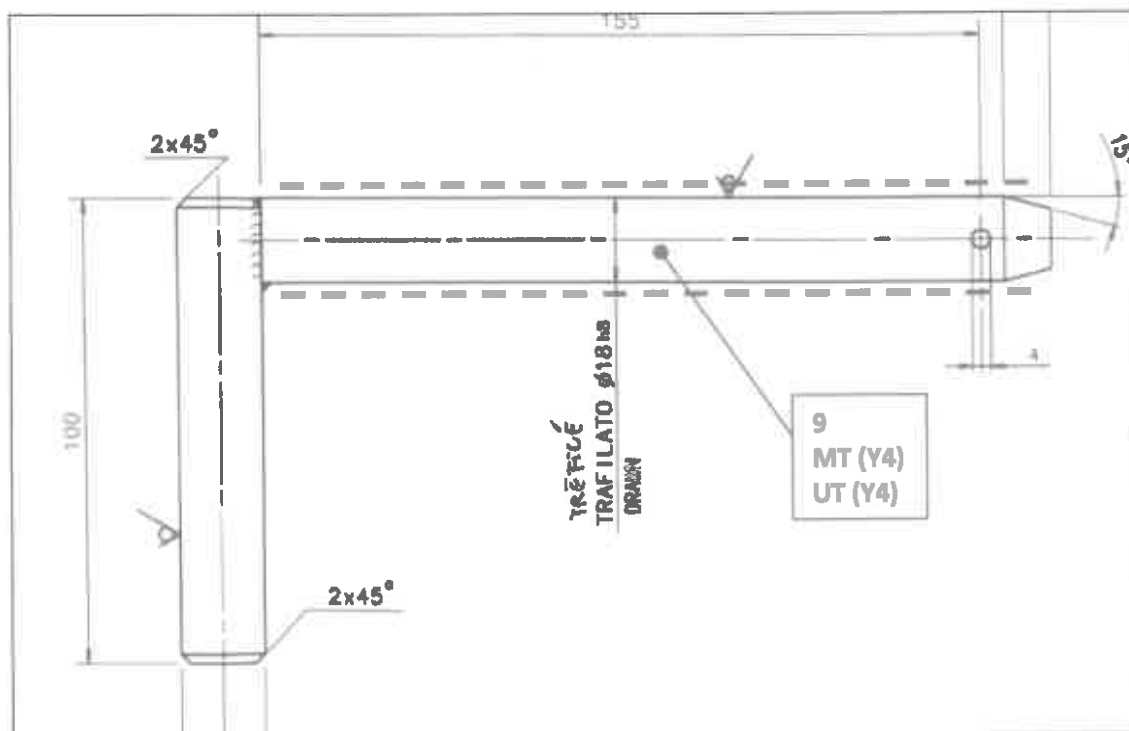
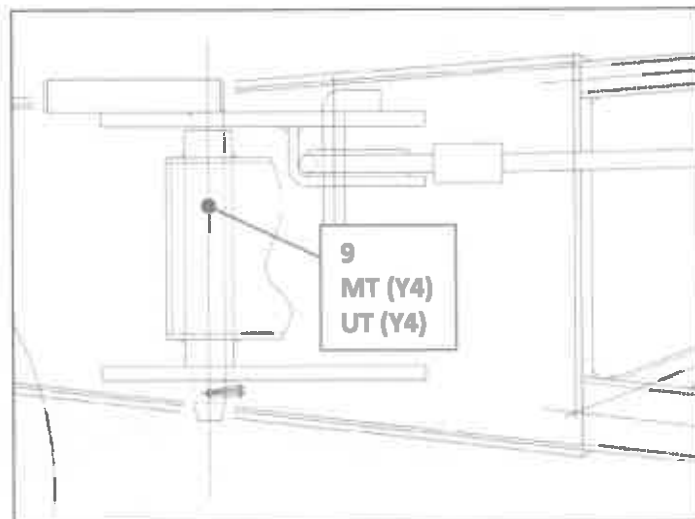

IMAGE 10 – TIE ROD PIN

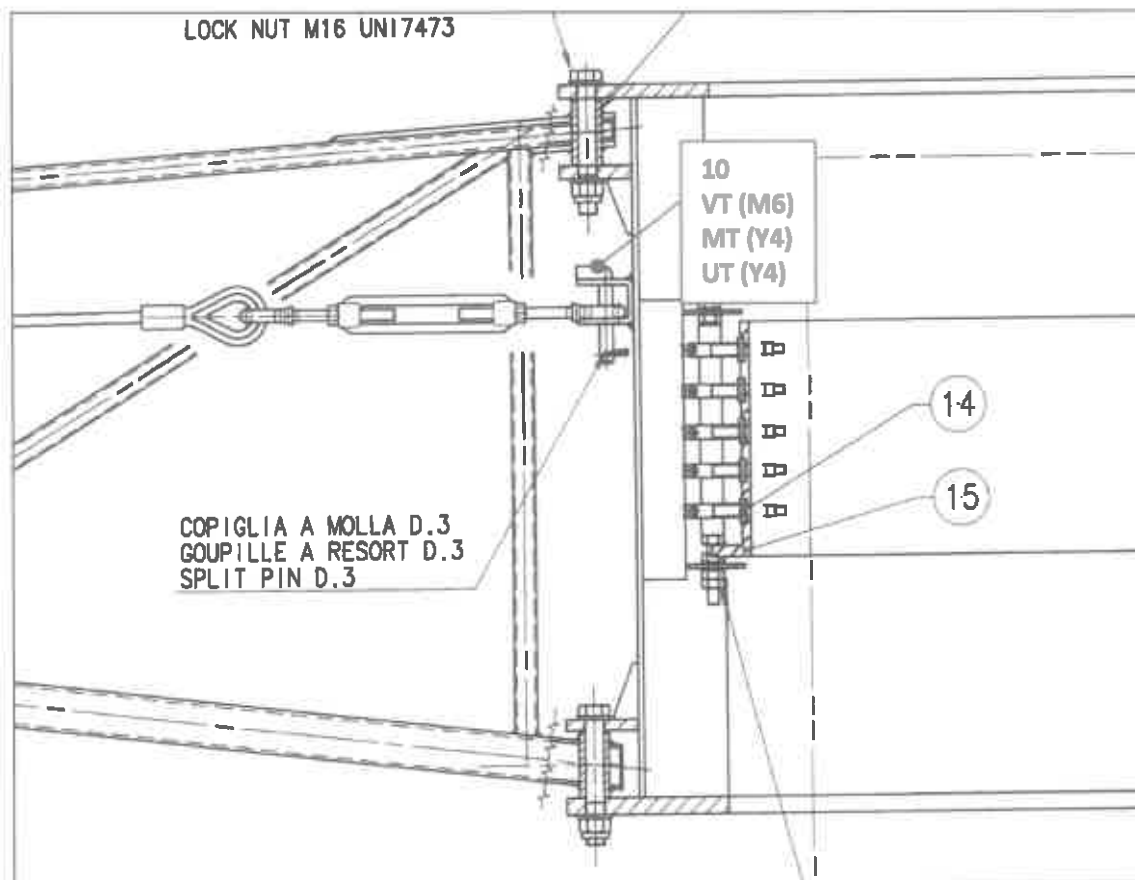
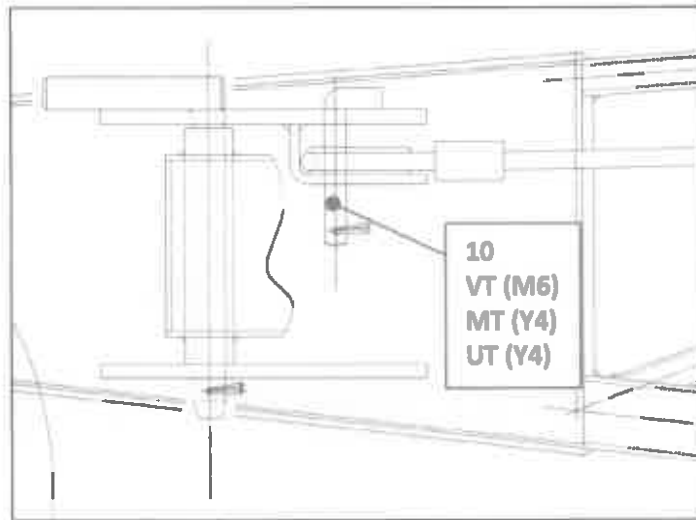

Image 10 – Tie Rod Pin (continuation)

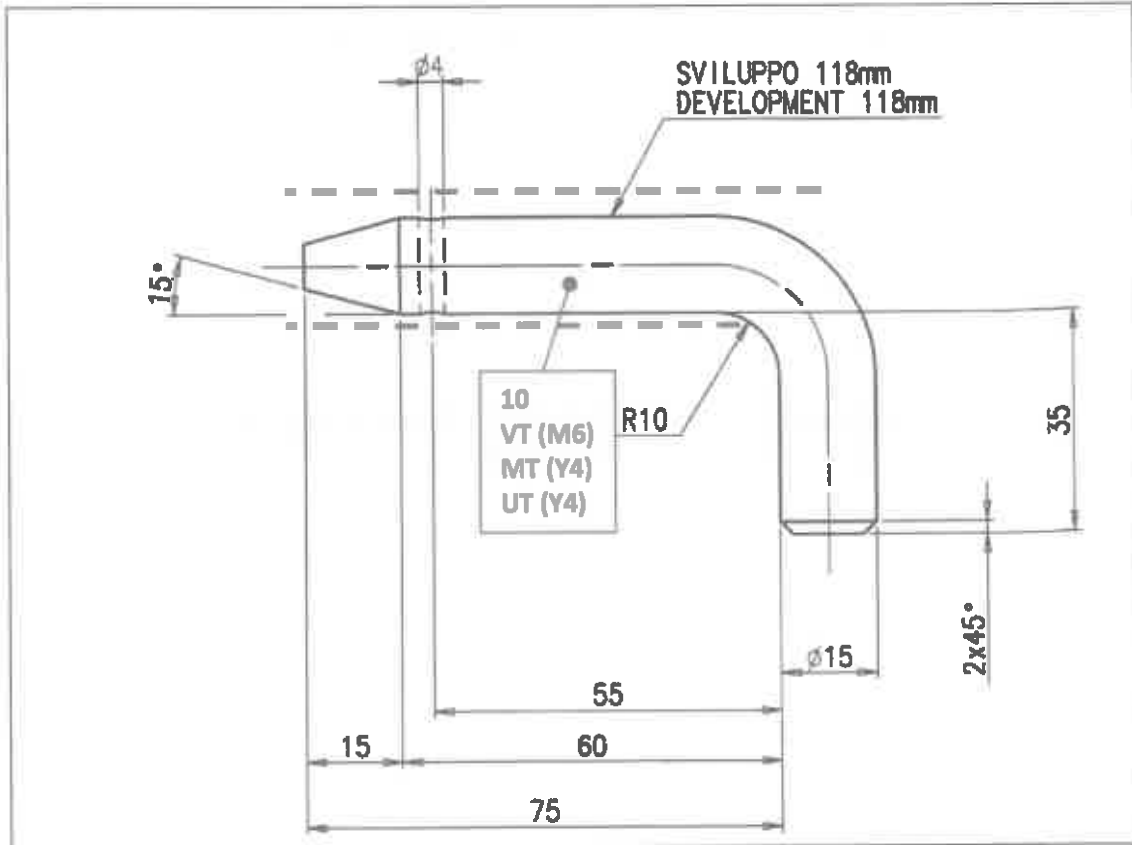

IMAGE 11 – TRUSS ARM PIN

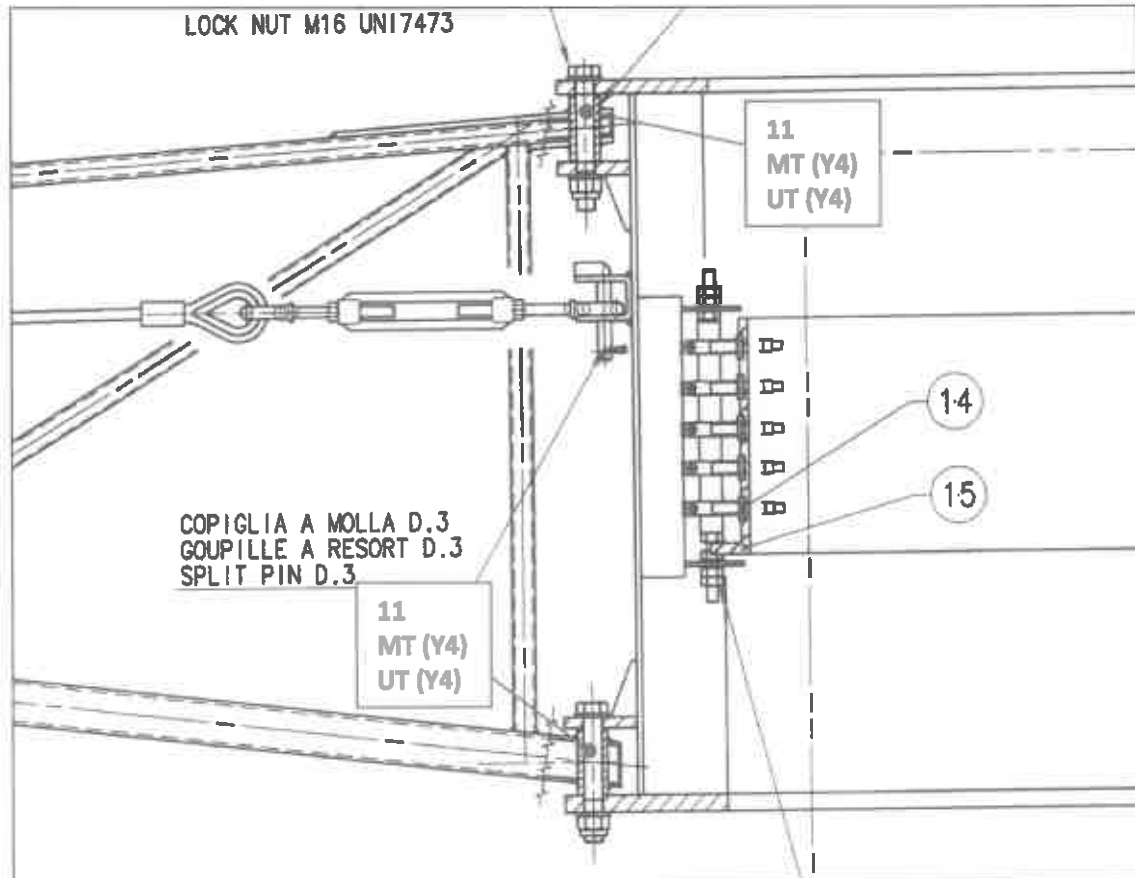

IMAGE 12 - ROTATING CENTRE

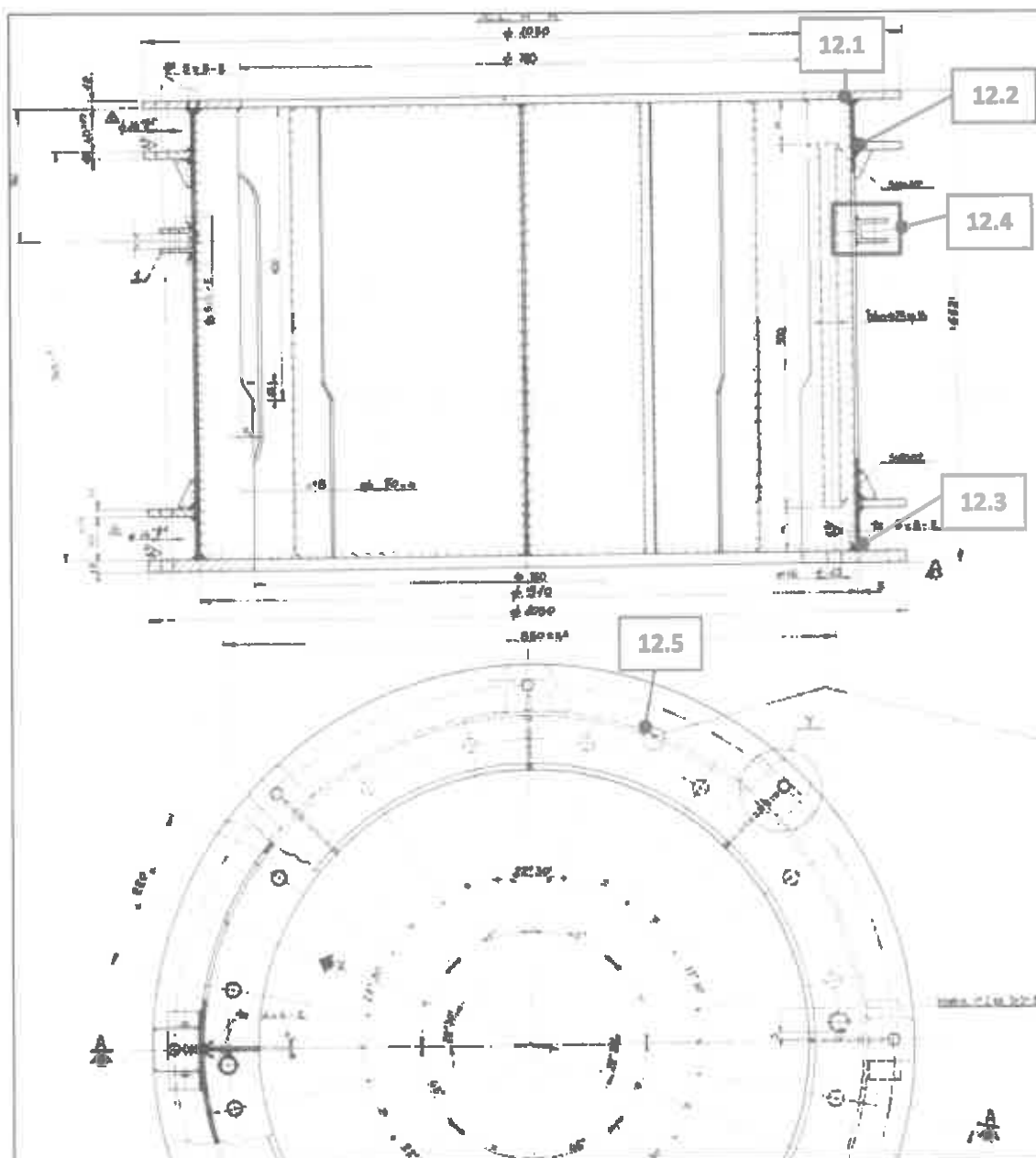

Image 12 – Rotating Centre (continuation)

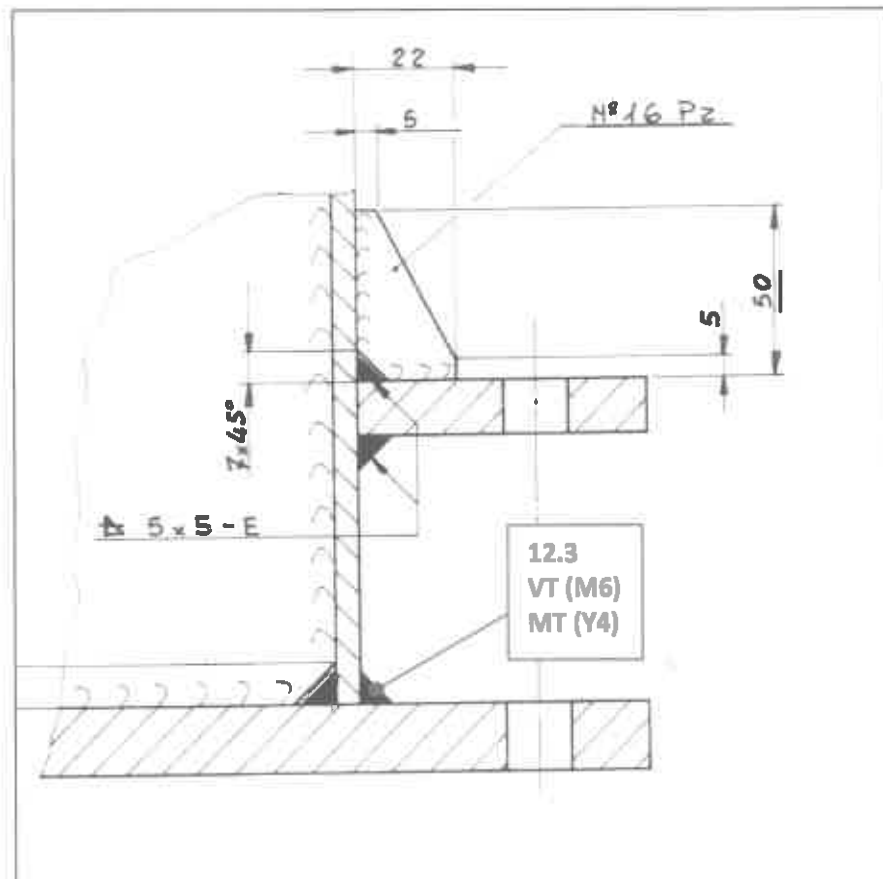
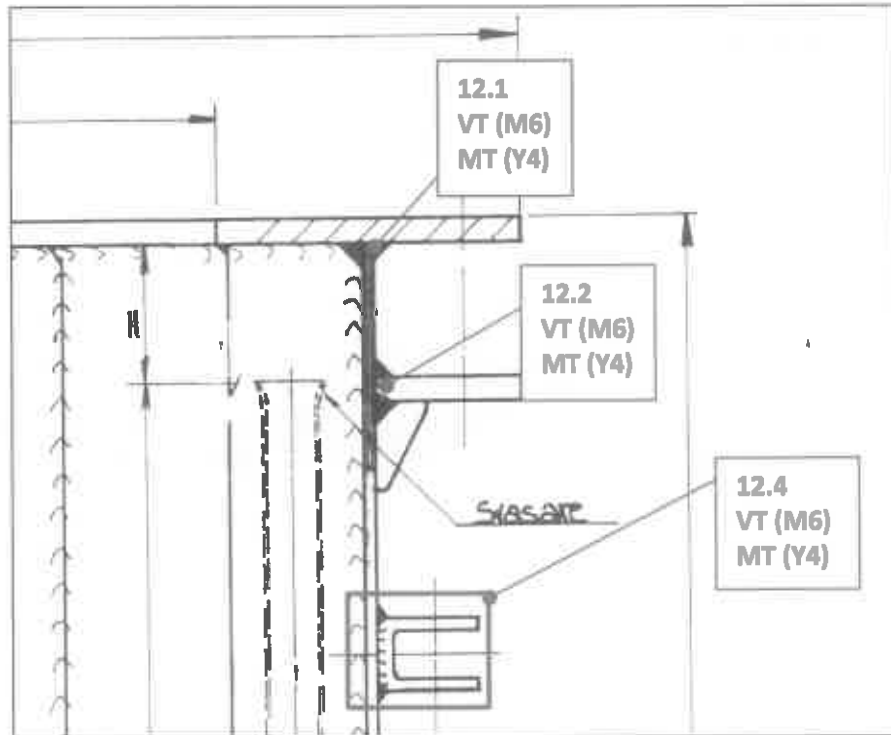

Image 12 – Rotating Centre (continuation)

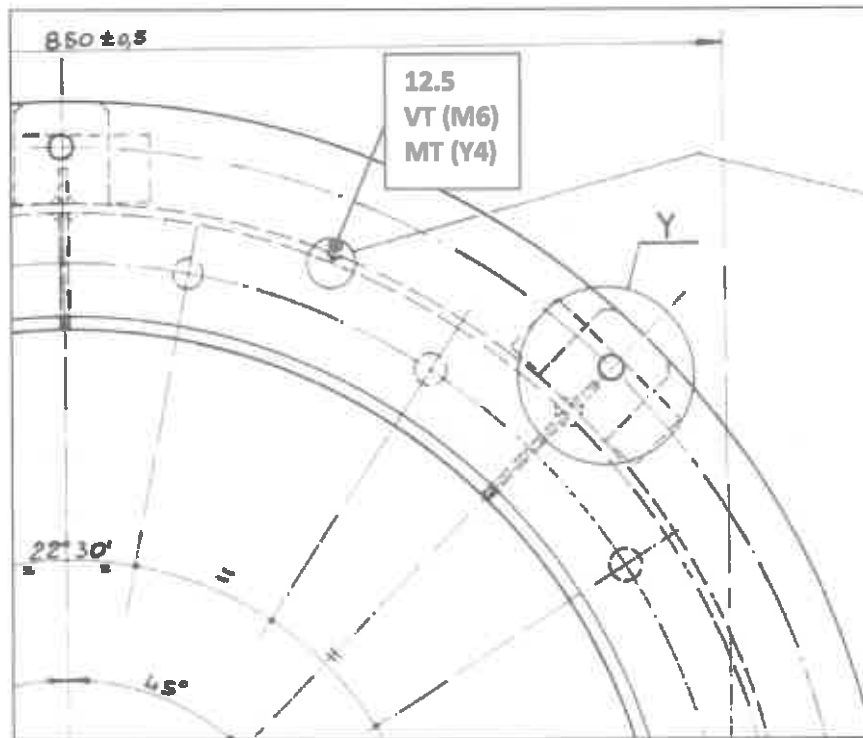

IMAGE 13 - FIXED CENTRE

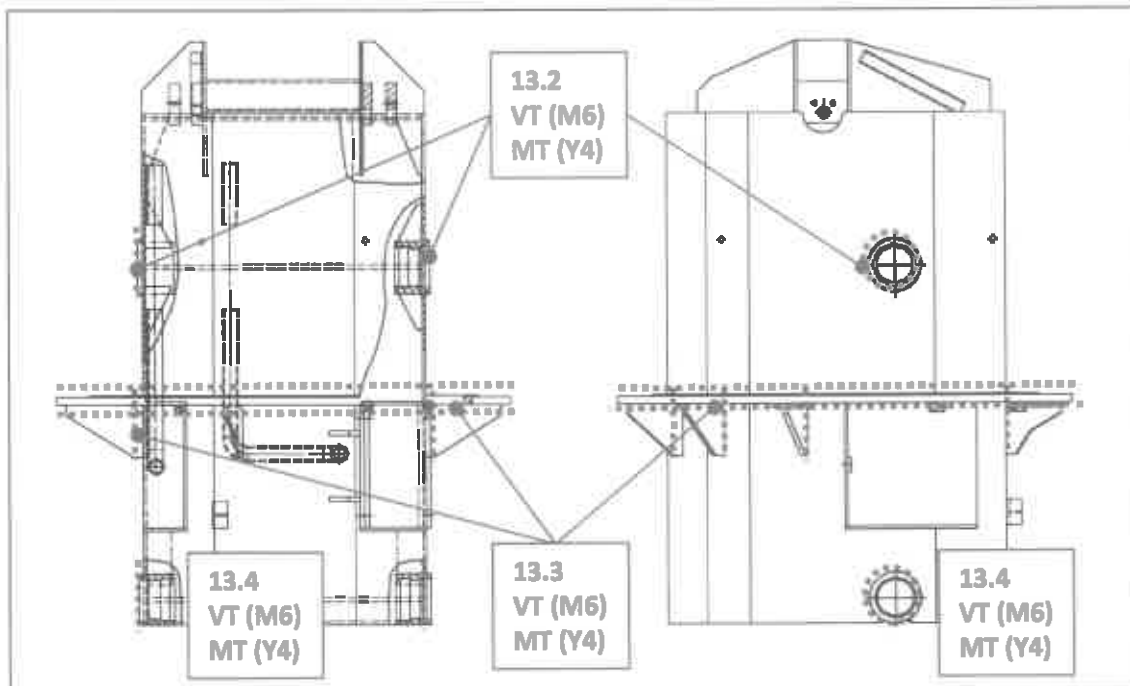
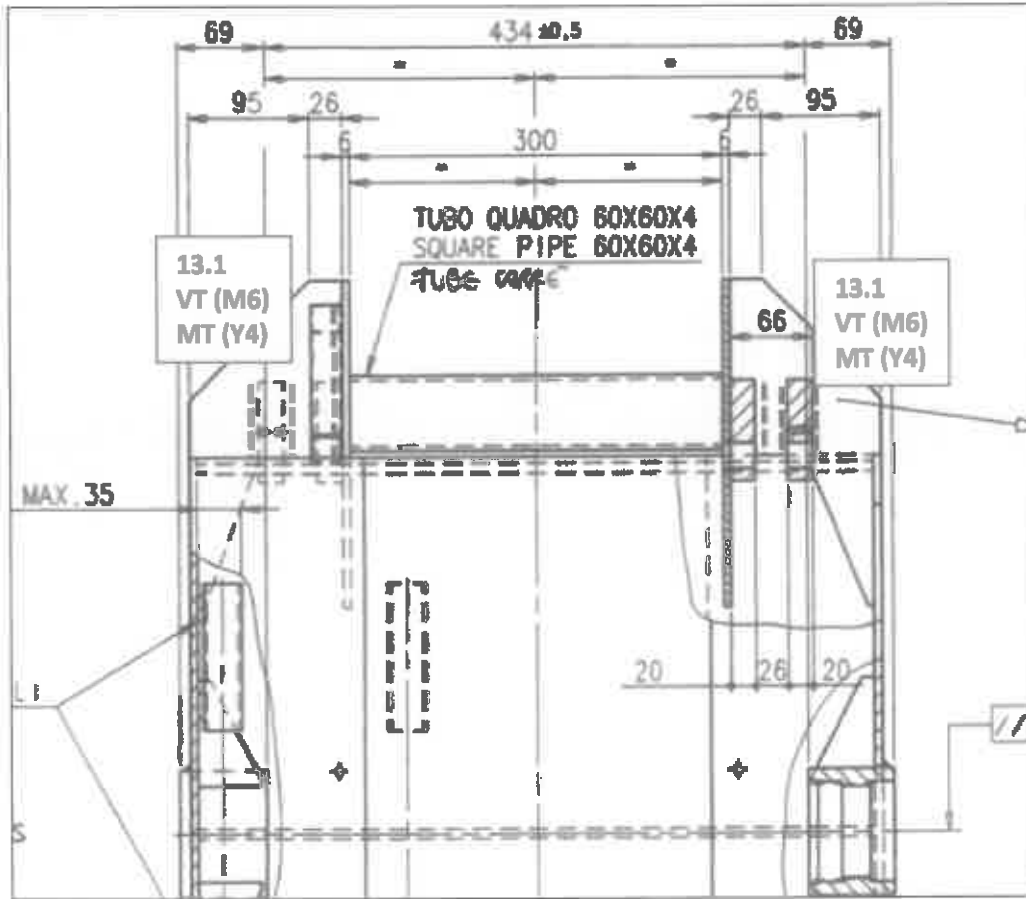

Image 13 – Fixed Centre (continuation)

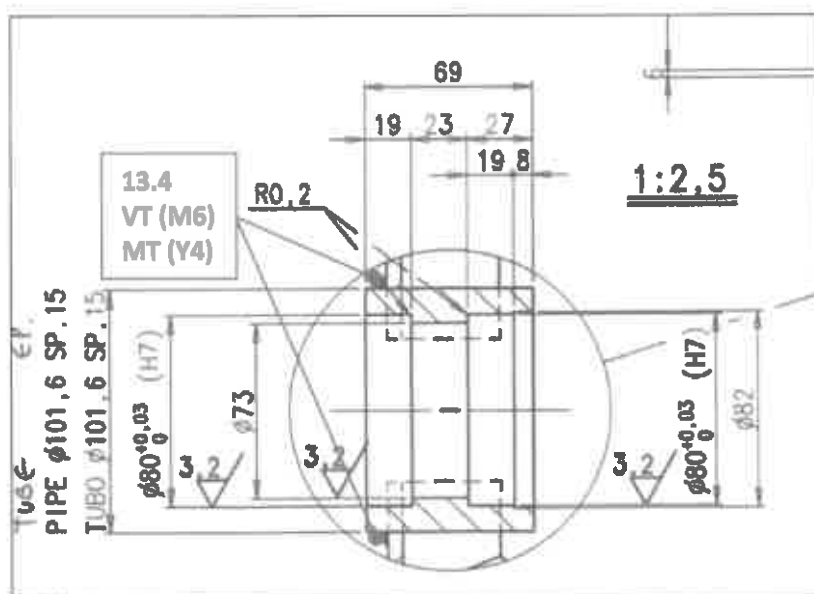
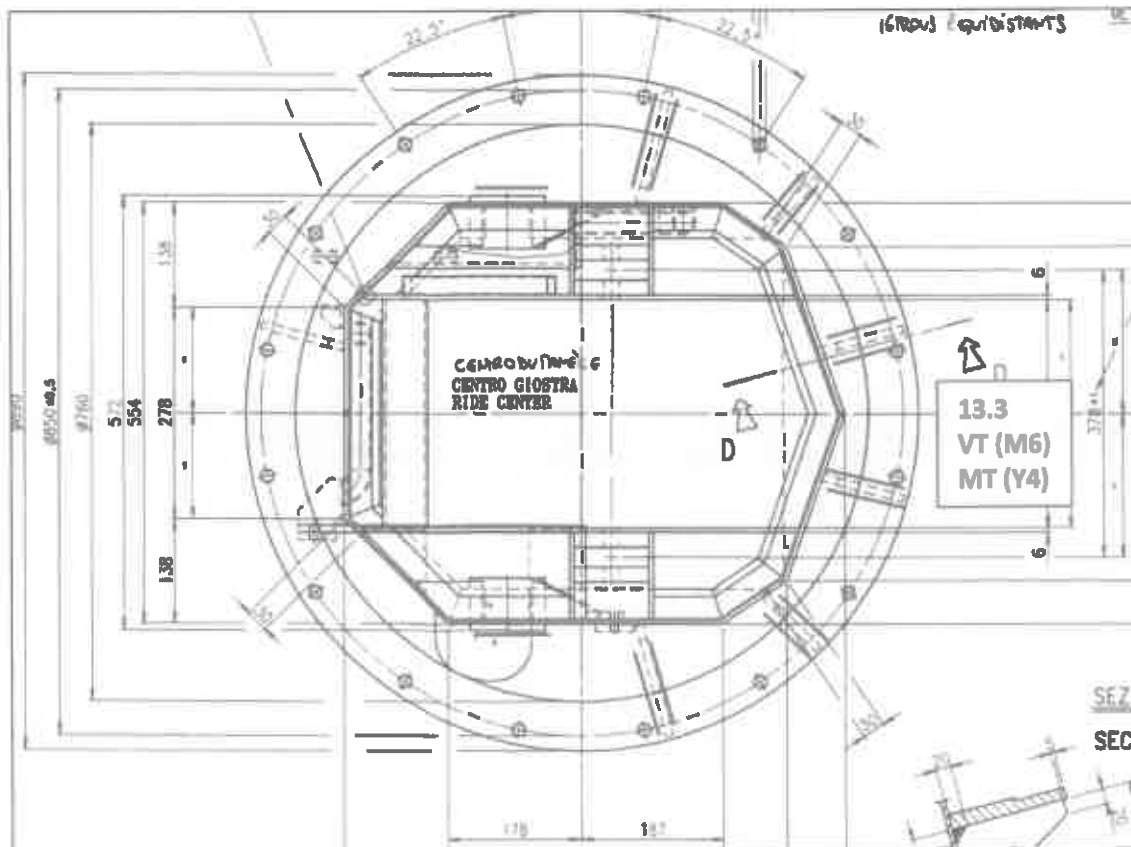

Image 13 – Fixed Centre (continuation)

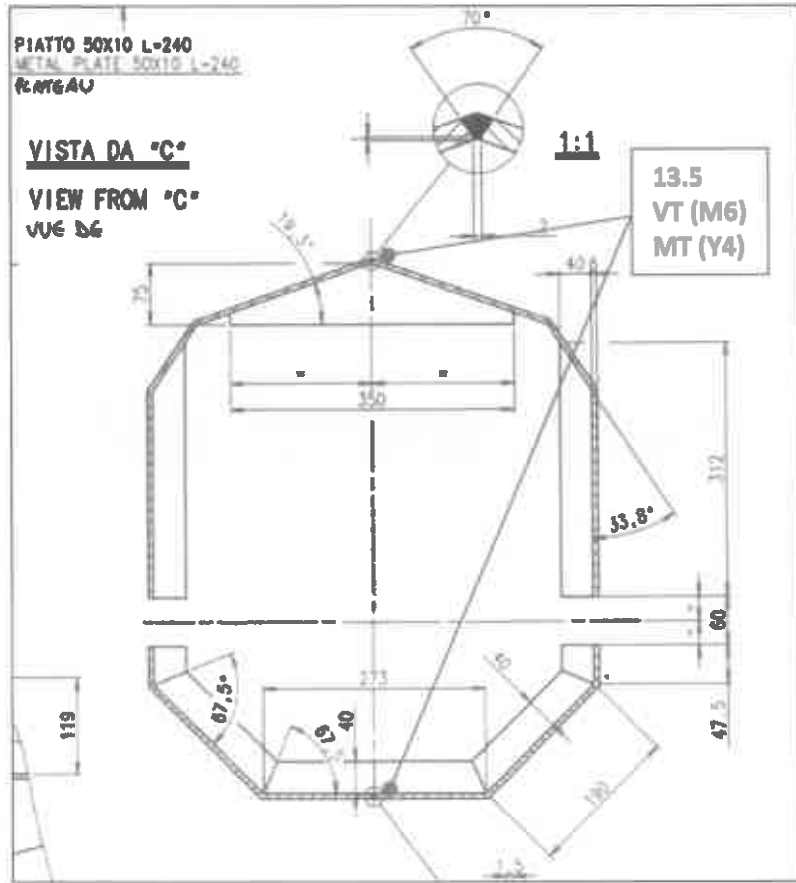

IMAGE 14 – WHEEL TROLLEY

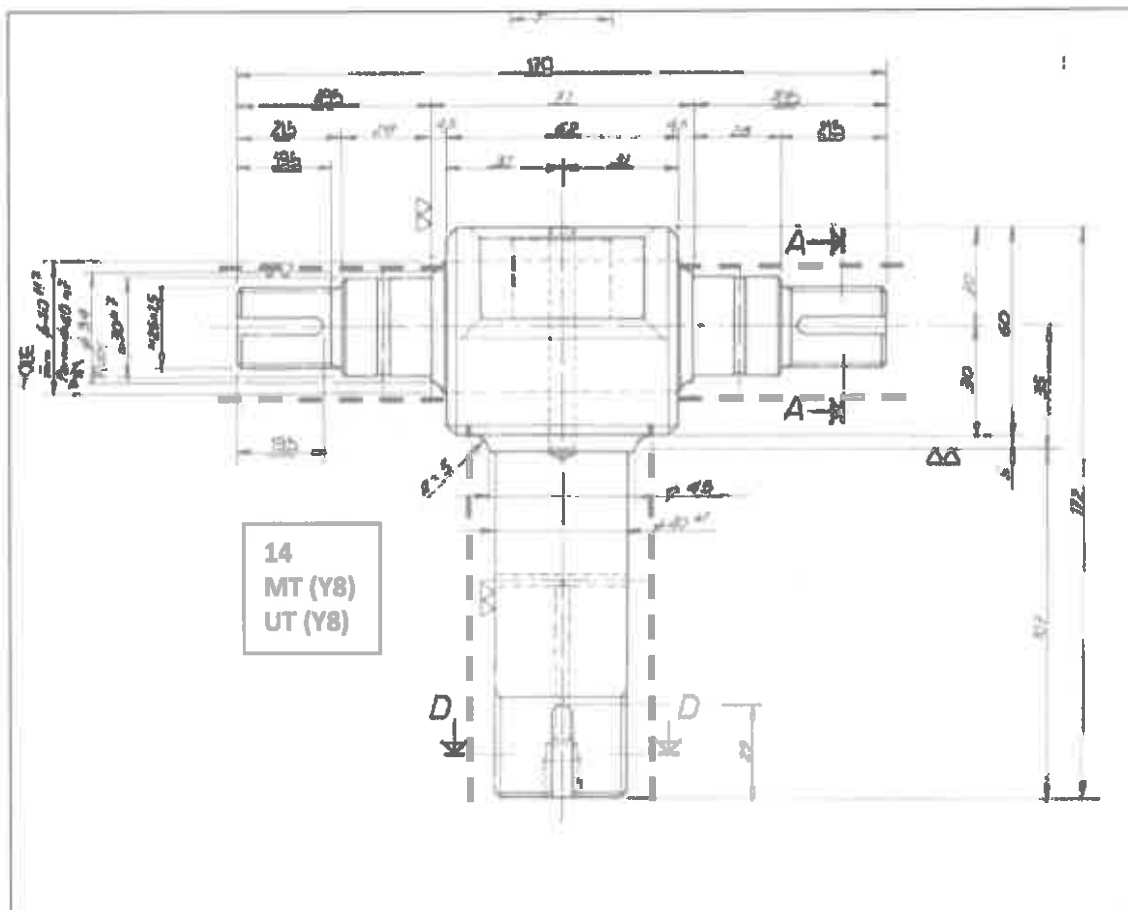
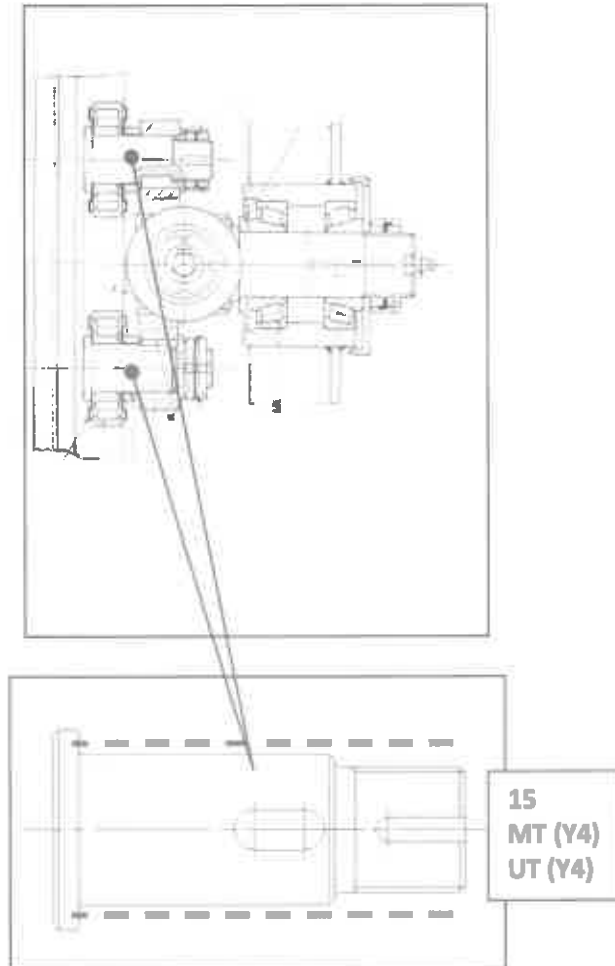

IMAGE 15 – WHEEL TROLLEY SUPPORT PIN



SAMBA BALLOON – NDT & Replacement Schedule Rev.3
IMAGE 16 – HYDRAULIC CYLINDER PIN

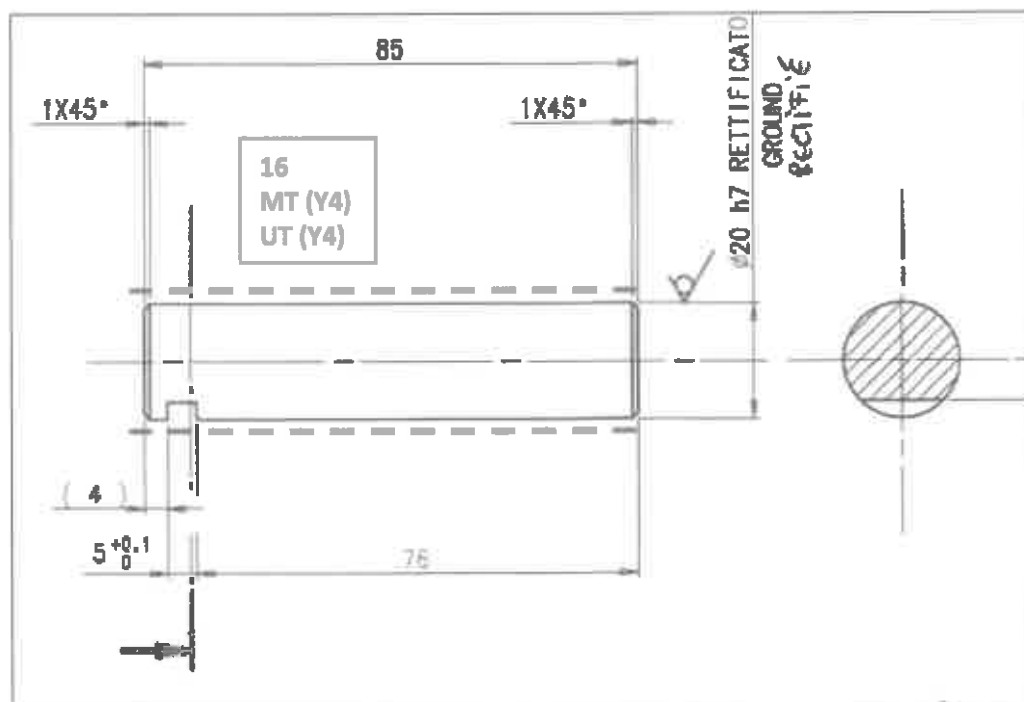
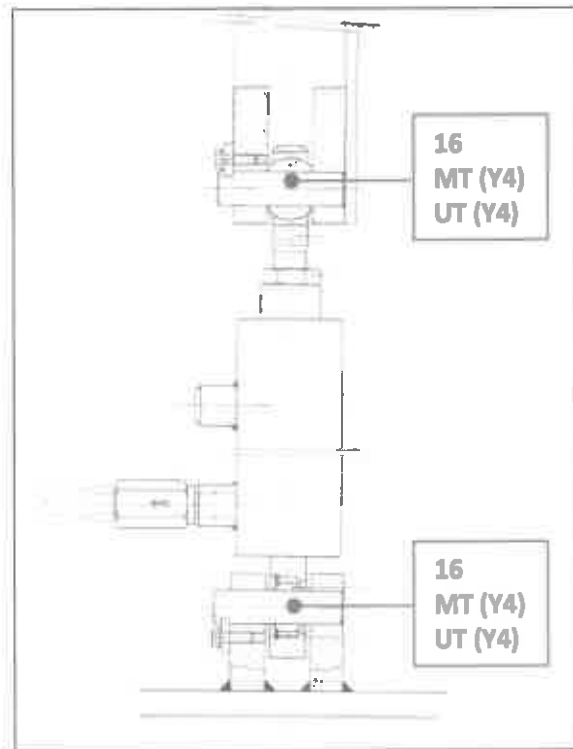

IMAGE 17 - COLUMN

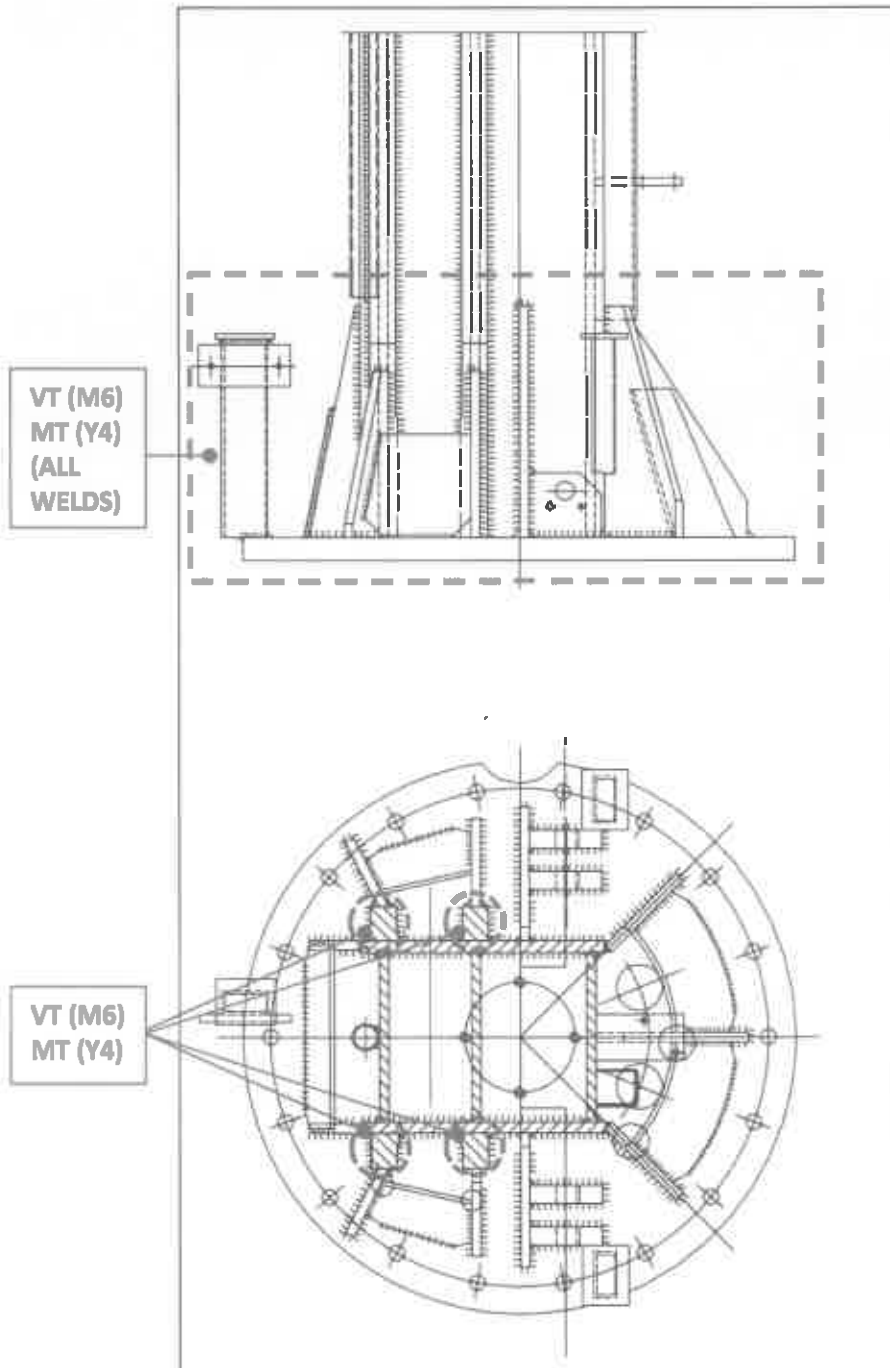

IMAGE 18 - BASE FRAME PARK MODEL (NEW DESIGN)

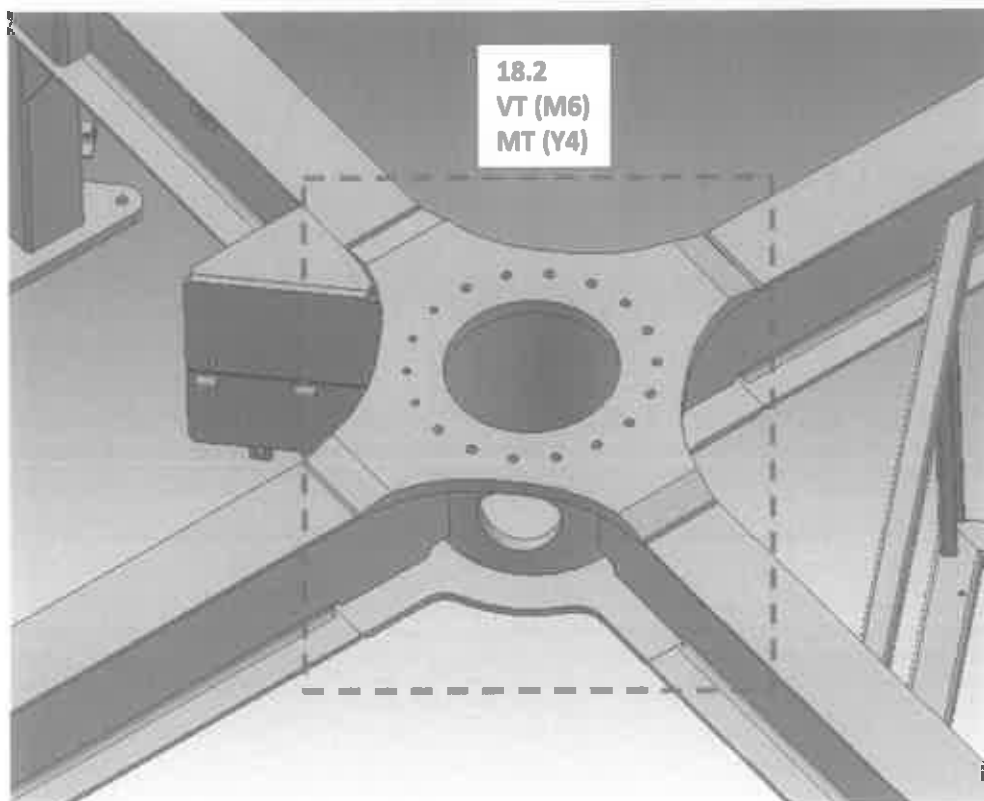
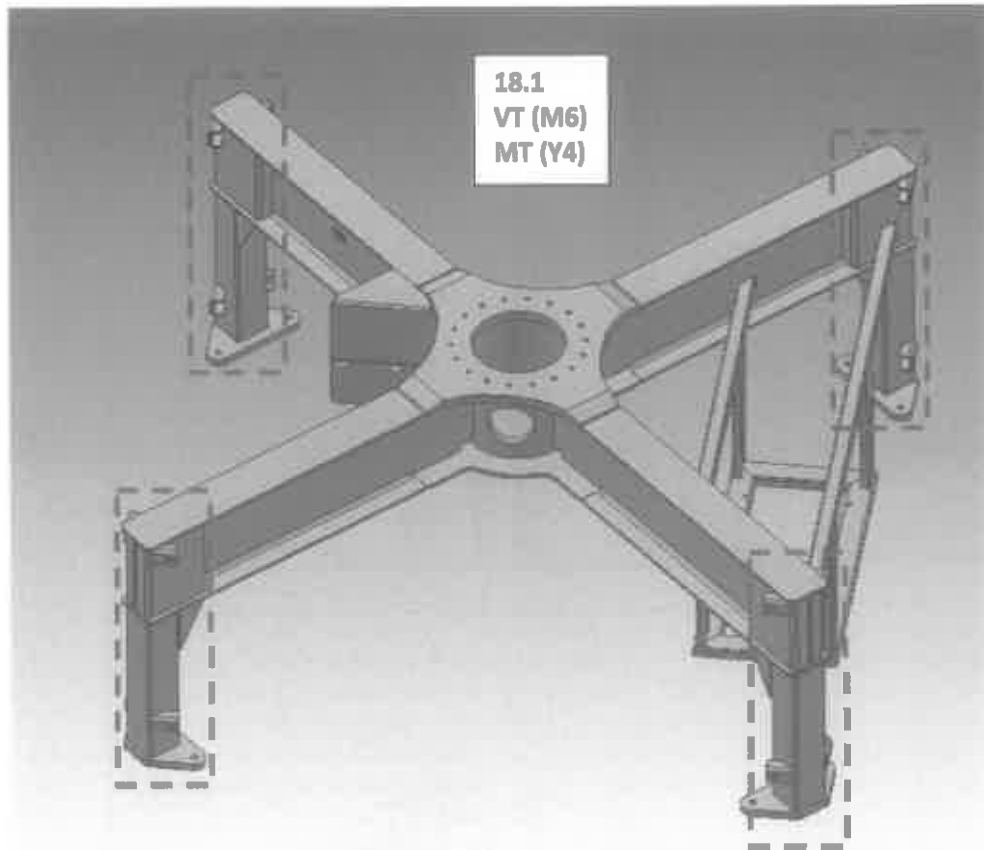
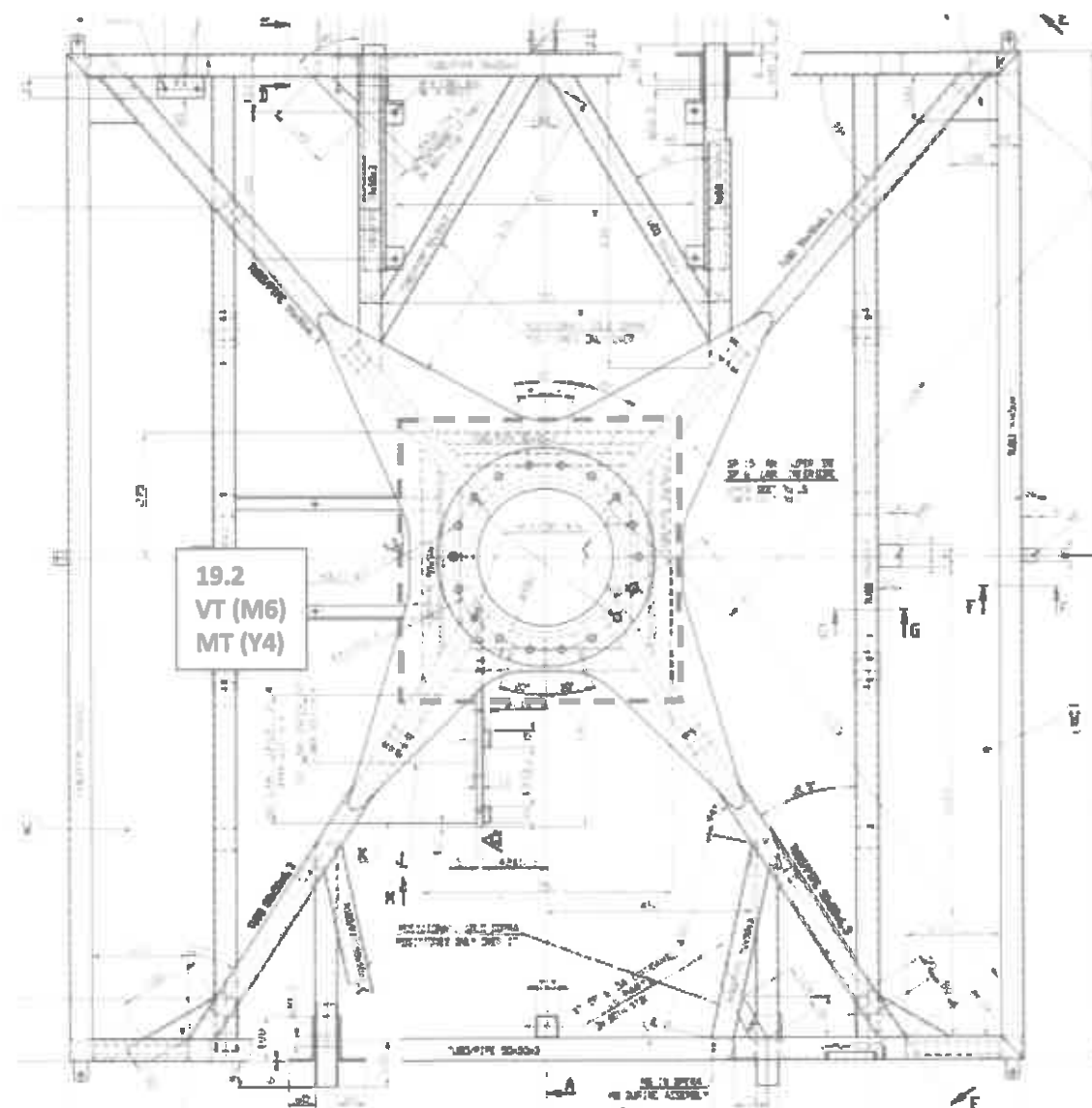
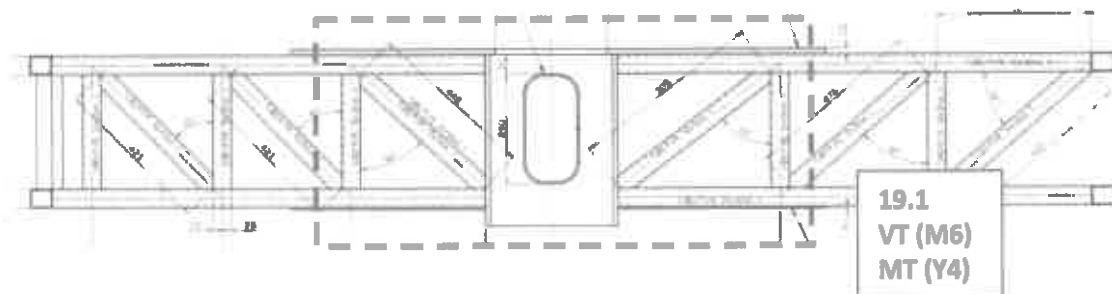

IMAGE 20 – BASE FRAME TRAILER MODEL



ZAMPERLA SERVICE BULLETIN SB-01-2018 NDT TEST ACCEPTANCE CRITERIA

Tab X.1 MT-W Magnetic Particle test on steel welds	
Type of Indication	Acceptance Limit
Linear Indication, l=length of indication (mm)	≤3
Non-linear Indication, d=major axis dimension (mm)	≤3

Tab X.2 PT-W Dye penetrant test on steel welds	
Type of indication	Acceptance Limit
Linear Indication, l=length of indication (mm)	≤4
Non-linear Indication, d=minor axis dimension (mm)	≤6

Tab. X.3 Magnetic Test on steel forgings and round bars	
Parameter	Acceptance Limit
Recording level minimum indication length (mm)	2
Maximum allowable length of isolated indications, L, and maximum allowable length of interacting indication, L _g (mm)	4
Maximum allowable cumulative length of indications in the reference surface (mm)	24
Maximum allowable number of indications in the reference surface	7

Tab. X.4 Dye penetrant test on steel forgings and round bars	
Parameter	Acceptance Limit
Recording Level mm (see Note 2)	≥3
Maximum allowable length L of isolated linear indications and maximum allowable length L _g of interacting indications mm (see note 2)	4
Maximum allowable cumulative length of linear indications in the reference surface mm (see Note 2)	24
Maximum allowable size of isolated rounded indications in mm (see note 2)	8
Maximum allowable number of recordable indication on reference surface (See Note 3)	7
Note 2 The tabulated values apply to the indication size, not to the surface extent of the flaw.	
Note 3 Reference surface = 148mm x 105mm (I.e. A6 format)	

Tab. X.5 UT-F Ultrasonic test examination by manual probe on ferritic and martensitic steel forgings	
Parameter	Acceptance Limit
Recording Level Equivalent Flat-bottomed holes (EFBH) d _{eq} in mm (See Note 1)	>3
Ratio R for rapid backwall echo reduction (See notes 2 and 3)	≤0.5
Acceptance Criteria	≤5
EFBH (isolated point type discontinuities) d _{eq} in mm (See Note 1)	≤3
EFBH (Extended or grouped point type discontinuities) d _{eq} in mm (See Note 1)	≤3
Note 1 d _{eq} = diameter of equivalent flat-bottomed hole.	
Note 2 R=F _r /F _{a,n} where: n=1 for t ≥ 60mm n=2 for t<60mm F _r = amplitude (Screen Height) of the n th reduced backwall echo F _{a,n} = amplitude (Screen height) of the n th backwall echo in the nearest discontinuity-free area at the same range as F _r	
Note 3 If the reduction in backwall echo exceeds the recording level, this shall be further investigated. Ratio R applies only to rapid reduction of backwall echo caused by the presence of a discontinuity.	

Tab. X.6 UT-R Ultrasonic test examination by manual probe on round elements ferritic and martensitic steel bars

Parameter	Acceptance Limit
Recording Level Equivalent Flat-bottomed holes (EFBH) d_{eq} in mm (See Note 1)	>3
Ratio R for rapid backwall echo reduction (See notes 2 and 3)	≤0.5
Acceptance Criteria	≤5
EFBH (isolated point type discontinuities) d_{eq} in mm (See Note 1)	≤3
EFBH (Extended or grouped point type discontinuities) d_{eq} in mm (See Note 1)	≤3
<p>Note 1 d_{eq} = diameter of equivalent flat-bottomed hole.</p> <p>Note 2 $R = F_n / F_{o,n}$ where: $n=1$ for $t \geq 60\text{mm}$ $n=2$ for $t < 60\text{mm}$ F_n = amplitude (Screen Height) of the n^{th} reduced backwall echo $F_{o,n}$ = amplitude (Screen height) of the n^{th} backwall echo in the nearest discontinuity-free area at the same range as F_n.</p> <p>Note 3 If the reduction in backwall echo exceeds the recording level, this shall be further investigated. Ratio R applies only to rapid reduction of backwall echo caused by the presence of a discontinuity.</p>	